

**LAKWOOD INSTRUMENTS
MODEL 2175Pe**

**MICROPROCESSOR-BASED
CONDUCTIVITY CONTROLLER**

INSTALLATION & OPERATION MANUAL

SERIAL #: _____



Lakewood Instruments

7838 North Faulkner Road, Milwaukee, Wisconsin 53224 USA

Phone (800) 228-0839 • Fax (414) 355-3508

<http://www.lakewoodinstruments.com>

Lakewood Instruments™ Model 2175Pe Controller

Quick Installation Sheet

1. Install the controller on a flat, non-vibrating surface. Use the four (4) surface mount tabs on the enclosure. Do not mount the controller to a steel object that has a large temperature change (side of cooling tower, etc). This can cause water to condense inside the enclosure.
2. Install water meters, chemical pumps, plumbing assemblies and the conductivity sensor (see drawing on back).
3. Wire the water meters (see drawing on back) and 4-20 mA output; if applicable. If a flow switch will not be used, attach a jumper wire to the flow switch input terminals. Ensure wiring connections are correct or damage may occur.
4. If doing a conduit installation, wire pumps and/or valves directly to the terminals. If using a motorized ball valve, wire as per wiring instructions. Refer to the instruction manual for more details.
5. Plug in chemical pumps and valves to controller (unless hardwired as per step #4).
6. Apply power to the model 2175Pe controller, press "**CLR**" twice, press "**7**" System setup, press "**2**" Initialization, press "**2**" Whole controller, press "**1**" Yes. After initialization, press the "**CLR**" key several times until you get to the main menu.
7. Press "**1**" Process, Press "**ENT**". This screen allows manual control of the relay outputs to test the chemical pumps and valves. Press "**CLR**" to return to the Process screen.
8. To calibrate the conductivity take a sample with a handheld conductivity meter, press the "**PRO**" button and type in the conductivity value, press "**ENT**".
9. Program the model 2175Pe relays for chemical feed schemes. See instruction manual for more details.

NOTES: UNLESS OTHERWISE SPECIFIED;

- 3 CUSTOMER SUPPLIED, 10K RESISTOR (PULL-UP).
- 4 ONLY OPEN COLLECTOR OUTPUT WATER METERS MAY BE USED.

REVISION HISTORY						
REV	ZONE	DESCRIPTION	EGG	DWN	DATE	APND
A		RELEASE	1121	EV	8/26/97	
B		REVISED	1285	EV	9/28/97	
C		REVISED	1387	EV	10/9/97	
D		REVISED	1438	EV	11/3/97	JGE
E		ADDED NOTE 3	1541	EV	2/16/98	JGB
F		REMOVED SIGNAL COND BOARD	1743	EV	8/18/98	

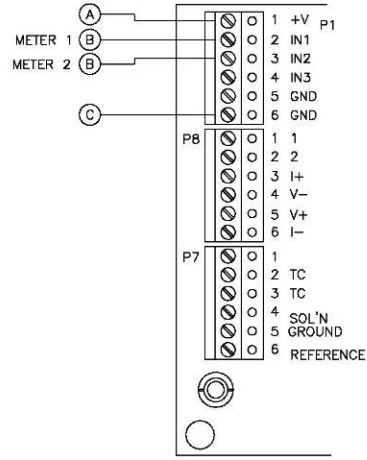
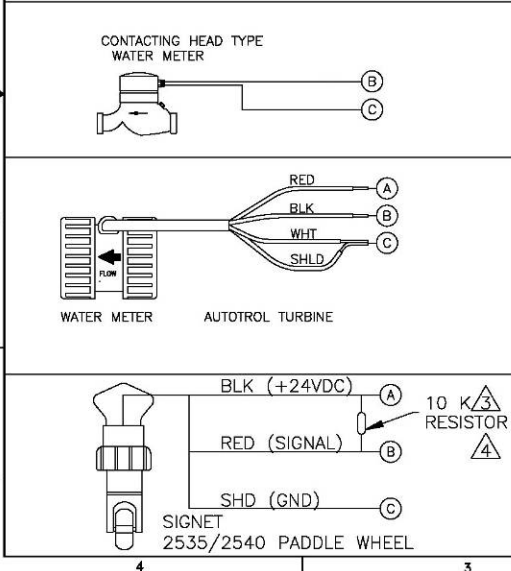

FIGURE A

IMPORTANT NOTICE

WARNING: CHEMICAL FEED

All electromechanical devices are subject to failure from a variety of causes. These include mechanical stress, component degradation, electromagnetic fields, mishandling, improper setup, physical abuse, chemical abuse, improper installation, improper power feeds, and exposure.

While every precaution is taken to insure proper functioning, extra precautions should be taken to limit the ability of over-feeding by limiting chemical quantities available, secondary shut-downs, alarms, and redundancy or other available methods.

CAUTION: POWER SOURCE AND WIRING

Low voltage wiring and high voltage (110 plus) should not be run in the same conduit. Always run separately. Even shielded low voltage is not a guarantee of isolation.

Every precaution should be taken to insure proper grounding and elimination of shorting or Electromagnetic field (EMF) interference.

WARNING: ELECTRICAL SHOCK

To reduce the risk of electrical shock, this equipment has a grounding-type plug that has a third (grounding) pin. This plug will only fit into a grounding-type outlet. If the plug does not fit into the outlet, contact a qualified electrician to install the proper outlet. **DO NOT** change the plug in any way.

Lakewood Instruments

We thank you for your selection and purchase of a Lakewood Instruments product.

With proper care and maintenance, this device should give you many years of trouble-free service. Please take the time to read and understand this Installation and Operation Manual, paying special attention to the sections on **OPERATION** and **MAINTENANCE**.

If, in the future, any parts or repairs are required, we strongly recommend that only original replacement parts be used. Our Customer Service Department is happy to assist you with your parts or service requests.

 **Lakewood Instruments Customer Service and Technical Support Departments can be reached by calling (800) 228-0839 or faxing (414) 355-3508, Monday through Friday, 7:30 a.m. - 5:00 p.m. CST. Our e-mail address is csd@lakewoodinstruments.com**

 **Mail should be sent to:**

**Lakewood Instruments
7838 North Faulkner Road
Milwaukee, WI 53224 USA**

MODEL 2175Pe

Table of Contents

1.0 Introduction	8
2.0 Features, Benefits and Specifications	9
2.1 Features	10
2.2 Benefits	10
2.3 Specifications	11
2.4 Ordering Information.....	12
3.0 Unpacking, Mounting and Installation	13
3.1 Unpacking	13
3.2 Mounting the Enclosure.....	13
3.3 Sensor Installation	14
3.31 Sensor Plumbing	14
3.32 Sensor Wiring	14
3.4 Electrical Installation.....	15
3.4.1 Incoming power 115/230 VAC	15
3.4.2 Relay Outputs	15
3.4.3 Flow Switch Wiring	16
3.4.4 Water Meter Wiring.....	16
3.4.5 4-20 mA Output Wiring	16
3.4.6 Node Wiring.....	17
4.0 Functional Overview.....	18
4.1 Display.....	18
4.2 Keypad	18
4.3 Menu	18
4.4 Security Levels	19
5.0 Starting Up the Controller.....	20
6.0 Operation of Controller	21
6.1 Process Screen	21
6.2 Manual Operation of the Relays	22
6.3 Calibration of CONDUCTIVITY	23
6.3.1 Calibration	23
6.3.2 Calibration Check in Buffer Solutions	23
6.3.3 Conductivity vs. ppm	24
6.4 Main Menu.....	25
6.5 Configuring the Relays	26
6.5.1 Configuring the Blowdown Relay.....	26
6.5.1.1 Disabled	26
6.5.1.2 By Tower Setpoint.....	27
6.5.1.2.1 Setpoint	27
6.5.1.2.2 Deadband.....	27
6.5.1.2.3 Blowdown Timeout.....	28

6.5.1.3	By Makeup Volume	28
6.5.1.4	Change My Name	29
6.5.1.5	Scheduled Lockout?.....	29
6.5.1.6	Blowdown By Cycle Setpoint	30
6.5.1.7	By Multi-Setpoint	31
6.5.2	Configuring Relays 2, 3, 4	32
6.5.2.1	Disabled	32
6.5.2.2	By Setpoint.....	32
6.5.2.2.1	Setpoint.....	33
6.5.2.2.2	Deadband	33
6.5.2.2.3	Overfeed Time	33
6.5.2.2.4	When to Activate	34
6.5.2.3	By Water Meter	34
6.5.2.4	By Percent of Blowdown Time	34
6.5.2.5	By Percent of Time.....	35
6.5.2.6	By Feed Schedule.....	36
6.5.2.7	As an Alarm Relay	36
6.5.2.8	Change My Name	37
6.5.3	Setting up the Feed Schedule.....	38
6.5.4	Alarms	40
6.5.5	Water Meters	41
6.5.6	4-20 mA Outputs.....	42
6.5.6.1	Setup of the 4-20 mA Output	42
6.5.6.1.1	Set the 4-20 mA Range.....	43
6.5.6.1.2	Calibrate.....	43
6.5.6.1.3	Which Process?	43
6.5.6.1.4	Manual Control.....	44
6.5.6.1.5	Change My Name	44
6.5.7	The System Setup Menu	44
6.5.7.1	Process Parameters.....	44
6.5.7.1.1	Change My Name	44
6.5.7.1.2	Preamp Setup	45
6.5.7.1.3	Temp Compensation	46
6.5.7.1.4	Cell Constant.....	46
6.5.7.1.5	Damping.....	47
6.5.7.1.6	Percent Per °C	47
6.5.7.2	Initialization	48
6.5.7.3	Digital Inputs	48
6.5.7.4	Firmware Versions	48
6.5.7.5	Change the Security Passwords	49
6.5.7.6	Diagnostics	49
6.5.7.7	Communications	49
6.5.7.7.1	Com Port Setup.....	50
6.5.7.7.2	Initialize Modem	50
6.5.7.7.3	Remote Password	51
6.5.7.8	Node Installation	51
6.5.8	Setting the Clock.....	51
6.5.9	Changing the Security Levels	52

7.0 Maintenance.....	53
7.1 Sensor Maintenance.....	53
7.2 Replacing the Fuse.....	53
8.0 Troubleshooting	54
8.1 Error Messages	54
9.0 Factory Service	56
10.0 Drawings	58
10.1 Installation Layout, 540 and 543 Sensors	1109745-1a
10.2 Wiring Diagram, Sensor Wiring	1268870-2a
10.3 Wiring Diagram, 540 Sensor Wiring	1268870-1a
10.4 Wiring diagram for water meter inputs	1109544-3f
10.5 Wiring Diagram	1268647-1a
10.6 Electrical Schematic.....	1268647-2a
10.7 Wiring Diagram RS2L Option	1109708-1d
10.8 Wiring Diagram RS2L Option	1109708-2c
10.9 Wiring Diagram 4-20 mA output, 35L	1109707-1b
10.10 Wiring Diagram NIN Option.....	1167855-1a

1.0 INTRODUCTION

The Model 2175Pe is a LONWORKS Technology, microprocessor based, menu driven, conductivity water treatment controller designed for use in process applications. The Model 2175Pe provides for conductivity tracking and control, flow monitoring and chemical injection. The Model 2175Pe is CSA and ANSI/UL approved.

The Model 2175Pe uses the latest in microprocessor capability, giving the user a high level of application flexibility. A large illuminated graphics screen, multiple inputs, and an intuitive menu characterize this new technology.

Security features allow full access to programming features or restrict access to viewing only. An operator password can help ensure that only authorized personnel will operate the system.

The Model 2175Pe is user-friendly with a graphical screen and 16-key numeric keypad. It accepts multiple inputs and is easily configured. This controller can easily be upgraded in the field. It's a combination of reliability, accuracy, security and simplicity.

LONWORKS Technology gives you a high level of flexibility with the capability of adding nodes, additional inputs and outputs, for monitoring and control. These nodes have functions such as extra relay outputs, drum level inputs, pH inputs, conductivity inputs, ORP inputs, 4-20 mA inputs and water meter inputs.

Nodes are added, using the –NIN option, according to a mapped network. The mapped network shows the full node addition capability of the LonWorks based 2000 series controllers.

The mapped network for the model 2175Pe shows that any or all of the following nodes can be added; two relay nodes, two 4-20 mA input nodes, two digital input nodes, four remote sensor nodes (any combination of pH, conductivity, or ORP), and one makeup conductivity node.

The complete mapped network is shown below.

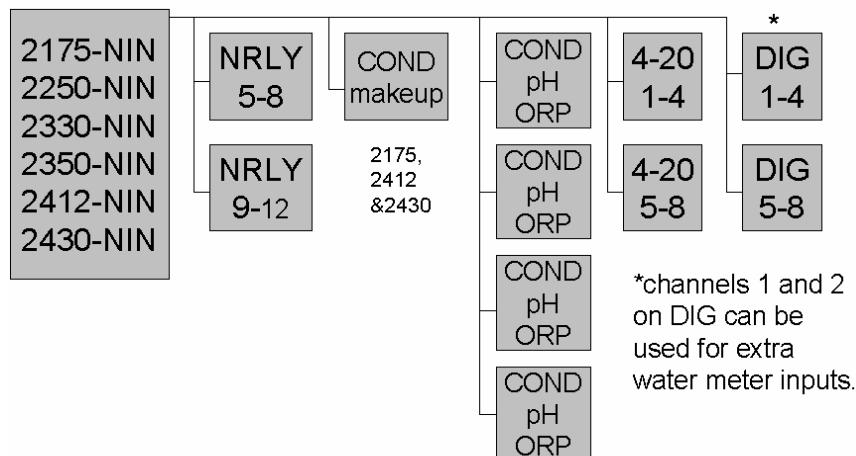

2.0 Features, Benefits, Specifications



Figure 1: *Model 2175e*

LOCK SCREWS

The lock screws keep your circuit boards secure and provide easy access for wiring and setup. Simply turn the lock screw and pull open the front panel.

16-BUTTON KEYPAD

ENT = for Menu selection and/or acceptance of selected values.

CLR = to exit a Menu selection and/or skip input options.

DSP = to change languages.

PRO = to program a Menu selection.

ENCLOSURE

A sturdy NEMA 4X rated enclosure protects your controller. Make sure it is properly mounted (SEE: **INSTALLATION; Mounting**). The power cord and receptacles can be removed so that the controller can be hardwired through ½" conduit knockouts.

2.1 FEATURES

- Conductivity input with fouling compensation and alarm.
- Two (2) water meter inputs. Records both makeup (**MTR1**) and Blowdown (**MTR2**) water meter total gallons.
- Configure Blowdown water meter (**MTR2**) as second makeup meter.
- One relay configured for bleed off and three user configurable relays for conductivity control and chemical addition. These relays can be configured in multiple ways including scheduled feed for biocide addition
- Blowdown Relay options:
 - Bleed x gallons for every x gallons makeup
 - Bleed x minutes for every x gallons of makeup
 - Bleed by setpoint
 - Bleed by cycles of concentration with **NCON/NCKT** Option
 - Bleed by multi-setpoint selected with **NCON/NCKT** Option
- User-selectable relay options:
 - Feed by setpoint, direct or reverse
 - Water meter actuated feed. **MTR1**, **MTR2** or the sum of the two
 - Percent of blowdown time
 - Percent of Time feed
 - Feed Schedule timer
 - General alarm
- Three security levels: View only, operator, technician
- 4-20 mA output available as an option.
- Remote communications available as an option.
- 16-key numeric keypad and illuminated graphical display allow for quick and easy programming.
- The Model 2175Pe controller stores all setpoints, calibration values, and relay configurations in an EEPROM. An EEPROM does not require a battery to retain information, so if power is lost these values will be retained for years. The 2175Pe includes a battery backup device to retain information such as water meter totals, and clock and calendar information. Battery life is approximately 3 months if no power is applied to the controller.

2.2 BENEFITS

- Multiple control options in a single economical package.
- Very accurate control of chemical feed and cycles of concentration.
- Feeds chemical after blowdown.
- Very low maintenance.
- Tolerant to power surges and brownouts.
- There is plenty of protected room inside the enclosure for electrician wiring.
- Very accurate monitoring of the evaporated water.
- Has expansion slots to add additional control, such as additional relay outputs, 4-20 ma outputs, remote sensor inputs, digital inputs, and 4-20 ma inputs.

2.3 Specifications

Conductivity range

Based on sensor used

540K.01 1-10 μ S

540K.1 10-100 μ S

543LL 10-500 μ S

543L 100-1,000 μ S

543M 500-100,000 μ S

Conductivity Resolution

Based on sensor used

1 μ S minimum

Accuracy & Repeatability

\pm 1.0% of scale

Deadband/Setpoint

User programmable

Auto/Manual outputs

Menu selectable

Keypad

16 - key push buttons

Display

Illuminated 128 x 64

pixel LCD

Water meter inputs (2)

Contact head, paddle wheel or turbine

Timer

Relay run time exceeded.

Output relays

1 Bleed off

3 selectable use

Relay ratings

3A each, 10A total

Power

120/240 VAC 50/60 Hz 6W

Ambiant temp

32° - 158°F (0 - 70°C)

Storage temp

32° - 158°F (0 - 70°C)

Max. Water temperature

140°F

Max. water pressure

140 psi @ 100°F

Languages

Selectable:

English, plus one of:

Spanish

German

French

Enclosure

NEMA 4X

2.4 Ordering Information

2175Pe LONWORKS Technology-based conductivity and water meter actuated chemical feed controller. The 2175Pe has built-in options for feed on conductivity, blowdown or makeup. Totalizing of makeup and blowdown, and three security levels are standard features. Conductivity range is 0-5,000 μ S. The standard unit does not have a receptacles or a power cord.

CONTROLLER OPTIONS

-35L Two 4-20 mA outputs configurable for remote data acquisition of Conductivity
-RS2L Communications node with shareware software
-NIN Network interface node. Allows 2 **NRLY**, 1 **Makeup NCON**, 4 sensor nodes (**NpH or NCON**), 2 **N420I** and/or 2 **NDIG** to be added.

LANGUAGE OPTIONS (optional, choose one, English and Spanish Standard)

-EF English and French.
-EG English and German.

REMOTE NODE OPTIONS (optional, MUST purchase -NIN Option)

NRLY Four additional relays with enclosure (2 per 2000 Series Controller).
NpH pH/ORP node for a pH or ORP sensor.
N420I 4-20 ma input node for up to 4 4-20 ma inputs.
NDIG Digital input node for up to 4 digital inputs.
NCON Conductivity node for makeup water or closed loop control (node only).
NCKT Conductivity node for makeup water or closed loop control with PVC sensor, tee and enclosure. Maximum water pressure is 140 psi @ 100 °F. Maximum temperature is 140°F.

NOTE: NOT FOR USE WITH MULTIPLE COOLING TOWERS.

SOFTWARE AND EXTERNAL MODEMS

LRWS *Windows*-based software for computer to communicate with 2000 Series Controllers
MD4X High-Baud modem in NEMA 4X enclosure ready to power
MD High-Baud modem for use with 2000 Series Controllers

3.0 Unpacking, Mounting and Installation

3.1 Unpacking

Inspect the shipping carton for obvious external damage. Note on the carrier's bill-of-lading the extent of the damage, if any, and **notify the carrier**. Save the shipping carton until your Model 2175Pe controller is started up.

☎ If shipping damage has occurred, call the Lakewood Instruments Customer Service Department at (800) 228-0839 and return the controller to the factory in the original carton.

3.2 Mounting the Enclosure

The Model 2175Pe is supplied with four mounting feet. The Model 2175Pe can be mounted to a panel or to a flat non-vibrating wall.

- Attach the four mounting feet to the back of the controller enclosure.
- Install on smooth surface to prevent stress on the mounting feet.
- Do not install on vibrating wall.
- If enclosure is installed in corrosive environments, consider purging.
- Dimensions indicated as inches (millimeters).
- The enclosure material is PVC.
- Use #10 mounting screws (4).
- Avoid drilling or punching additional holes in the controller enclosure. Damage incurred as a result of any alteration to the enclosure is not covered under the Lakewood Instruments product warranty.

The dimensions of the enclosure in inches are:

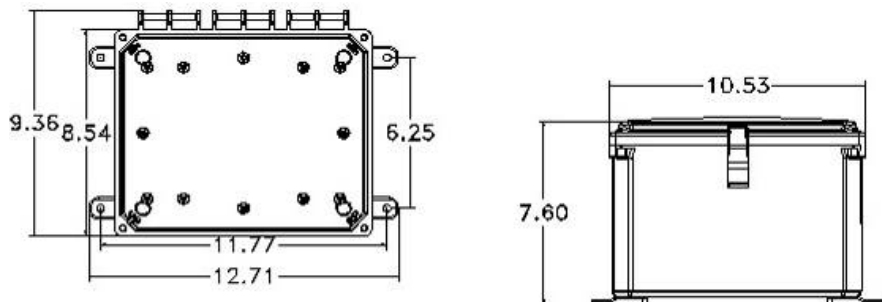

The model 2175Pe has a shipping weight of about 8 lbs.

NOTE: EXCESSIVE HEAT AND/OR DIRECT SUNLIGHT EXPOSURE WILL DARKEN THE LCD DISPLAY SCREEN, MAKING IT DIFFICULT TO READ, AND MAY SHORTEN THE LIFE OF OTHER ELECTRONIC COMPONENTS.

3.3 Sensor Installation

3.3.1 Sensor Plumbing

The Conductivity sensor may be mounted in any position as long as the sensor tip is fully immersed in the active process water stream. Avoid connections in “dead leg” sections of pipe. An air pocket around the electrode tips will cause erroneous readings. The sensor electrodes should be in direct contact with the process flow (see DWG #04259 in the back of this manual).

Note: Remember to install isolation and bypass valves so that maintenance can be performed.

3.3.2 Sensor Wiring

The model 2175Pe will accept the model 540K.1, the model 540K.01, the model 543M, the model 543L, and the model 543LL conductivity sensors. The conductivity sensor is wired directly to the I/O board inside the controller.

The 543 series sensors have 6 wires. They are as follows:

- Black wire Electrode
- Red wire Electrode
- White wire Electrode
- Green wire Electrode
- Black wire Temp compensation
- Black wire Temp compensation

The 540 series sensors have 4 wires. They are as follows:

- Black wire Outer Electrode
- Red wire Center Electrode
- White wire Temp compensation
- Green wire Temp compensation

For wiring instructions please refer to the drawings at the back of this manual.

The maximum allowed cable length between the sensor tip and the controller is twenty (20) feet. Cable length of conductivity sensors is measured from the electrode tips to the end of the wire. Lakewood Instruments guarantees operation up to 20 feet. If a cable extension is used, Lakewood Instruments will not guarantee operation of the sensor.

3.4 Electrical Installation

3.4.1 Incoming Power 115/230 VAC

The Model 2175Pe can be powered from either 115 VAC or 230 VAC at 50/60 Hz. The Model 2175Pe controller comes with a power cord and receptacles. The power cord and receptacles are rated for 115VAC. If the controller will be powered by 230 VAC, the power cord and receptacles will need to be removed and the incoming power and the relay outputs will need to be hard-wired.

The incoming power is connected to terminal block TA at the bottom right corner of the power supply board. There is a hot or line input (terminal 4), a neutral input (terminals 2 and 3) and an earth ground input (terminal 1). The hot is wired to the fuse holder located on the bottom of the enclosure. The neutrals are wired directly to terminals 2 and 3 of terminal block TA. Refer to the drawing in the back of this manual for wiring instructions.

3.4.2 Relay Outputs

The relay outputs are of the same voltage as the power input. Ensure that the devices that are to be connected to the relay outputs are of the same voltage rating or damage will occur.

The relay outputs are wired to the receptacles. The receptacle on the far left is relay #1 and the receptacle on the far right is relay #4. On the power supply board, relay #4 is on the far left and relay #1 is on the far right. If 115 VAC is used simply plug your devices into the molded receptacles. If 230 VAC is used, remove the receptacles and hard-wire your devices to the relay outputs.

Relay #1 and #2 have both a normally open and normally closed contact. This is designed for use with motorized valves. The normally open (NO) contact is connected to the open connection of the valve and the normally closed (NC) contact is connected to the close connection of the valve. The other two relays only have a normally open contact. Each relay output requires a neutral connection and an earth ground connection for proper operation.

Refer to the drawing in the back of this manual for wiring instructions.

<p>WARNING! <u>DO NOT</u> PLUG IN CHEMICAL PUMPS THAT ARE LARGER THAN 1/6 HORSEPOWER. THE CONTROL RELAYS ARE INTENDED FOR ELECTRONIC OR SMALL MOTOR-DRIVEN CHEMICAL PUMPS. LARGER PUMPS REQUIRE THE -HR OPTION WITH 25-AMP-RATED INTERPOSING RELAYS. CONTACT LAKEWOOD INSTRUMENTS FOR SPECIAL INSTRUCTIONS.</p>
--

3.4.3 Flow Switch Wiring

The model 2175Pe has a flow switch input. The purpose of the flow switch input is to disable the relay outputs on a loss of flow in the system. The flow switch input requires a digital contact. Any digital contact rated for 24 VDC and 500 mA may be used, such as a relay driven by the recirculation pump.

If a flow switch is not used then a jumper must be installed across the flow switch connections. Refer to the drawings in the back of this manual for wiring instructions.

3.4.4 Water Meters

The Model 2175Pe will accept two water meter inputs. These inputs can be configured for make-up, make-up Second Source, Bleed, or Chill Loop make-up. Refer to the water meter manufacturer's manual for plumbing information.

The 2175Pe series controllers will work directly with the following types of meters: dry contacting head meters, Seametrics open collector output meters, Signet 2535 and 2540 paddle wheel meters, and the Autotrol 1 inch and 2 inch meters. Contact Lakewood Instruments for other types of water meters. The water meters are wired to terminal block P1 which is the top terminal block on the I/O board.

Refer to the drawing in the back of this manual for wiring instructions.

3.4.5 4-20 mA Output Wiring

If the -35L option is ordered, the model 2175Pe has two channels of 4-20 mA output. This output can be isolated (externally powered) or non-isolated (internally powered). The 4-20 mA outputs are wired directly to the -35L option card.

Refer to the drawing in the back of this manual for wiring instructions.

3.4.6 Node Wiring

If the –NIN option is ordered with any external nodes (NpH, NCON, NRLY, NDIG, or N420I) they must be wired to the controller before installation and programming can take place. Nodes require +24 VDC for operation and twisted pair wire for data transmission. The NIN option card can provide the +24 VDC for up to two nodes using non-twisted pair wire. If using three or more nodes an external +24 VDC power supply run in parallel is recommended.

Recommended twisted pair data specifications are:

Beldon 85102, single twisted pair, stranded 9/29, unshielded, plenum.

Beldon 8471, single twisted pair, stranded 9/29, unshielded, nonplenum.

JY (ST) Y 2 X 2 X .8, UL Level IV 22 AWG, twisted pair, typically solid and unshielded.

Four wire helical twist, solid, shielded.

If shielded cable is used, the shield should be connected to earth ground via a 470K ohm, .25 watt, metal film resistor to prevent static charge buildup.

Nodes are wired directly to the NIN card inside the controller enclosure.

Please refer to the diagram in the back of this manual for wiring instructions.

4.0 Functional Overview

4.1 Display

The model 2175Pe uses an illuminated 128x64-pixel LCD digital display for ease of viewing. It has multiple lines to display information such as the conductivity reading, alarms, relay status, relay configuration, clock, flow totals for both water meters, and menu selections.

4.2 Keypad

The model 2175Pe uses a 16-key numeric keypad for ease of programming. The keys have the following functions:

ENT	To accept a setting or to enter a screen.
CLR	To exit a screen or to access the main menu.
PRO	To calibrate the controller.
DSP	To change languages.
UP arrow	To move about in the menu.
DOWN arrow	To move about in a menu.
Number keys	To input a value or to select a menu item.

4.3 Menu

The model 2175Pe is programmed and calibrated by the use of a menu. The complete **Main Menu** has 8 available options that can be accessed in the **Technician Level**. However, a list of only six options can be viewed at one time. Use the **↑** and **↓** keys to scroll through the options. As an introduction, here is a graphic overview of the first level of each option in the **Main Menu** to see how it operates. Complete details of each option are provided later in this manual.

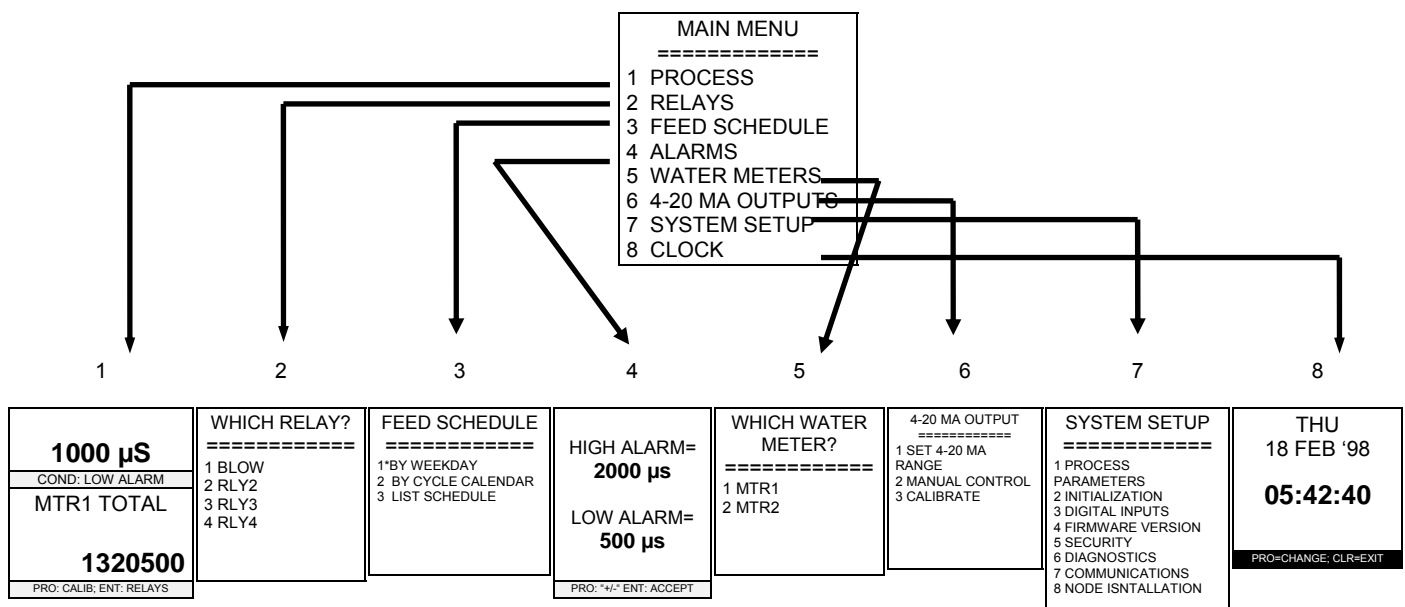

4.4 Security Levels

The model 2175Pe has a security levels to prevent tampering of the controller. The Model 2175Pe offers three (3) security levels: 1) **View Only**, 2) **Operator** and 3) **Technician**.

When the controller is in the **View Only** or **Operator** security level, the menu is locked out.

In **View Only**, access is limited to manual operation of the relays, and viewing all of the process screens.

In the **Operator** mode the user can operate the relays manually, view the process screens, and calibrate the controller. He cannot change any other settings.

In the **Technician** mode the operator has full access to all of the menus.

A password is required to change from a tight security level to a less restrictive security level. Each level has its own factory-preset password (2222 for Technician, 1111 for Operator). If the controller is in the **View Only** or **Operator** mode just press the appropriate password on the keypad to change to a less restrictive security mode.

The passwords can be changed to personalized passwords from the **Technician Level Menu**.

NOTE: IF YOU USE PERSONALIZED PASSWORDS, MAKE SURE THEY ARE RECORDED IN A SAFE AND SECURE PLACE.

5.0 Starting Up the Controller

Once the Installation is complete it is time to start up the controller.

Initiate sample flow to the conductivity sensor. Check for leakage.

Power up the controller by either turning on the circuit breaker or plugging the power cord into a 120 VAC receptacle.

It is best to initialize the whole controller to remove any settings that may be in the memory before programming the controller. Refer to section 6.5.7.2 of this manual to initialize the controller.

Set up the internal preamp as per section 6.5.7.1.2.

Set up the temperature compensation as per section 6.5.7.1.3.

Set up the cell constant as per section 6.5.7.1.4.

If applicable, install each node in software. Refer to the appropriate node manual for installation instructions.

Set the clock by following section 6.5.8.

Set the high and low conductivity alarms by following section 6.5.4.

Configure the relays for operation by following section 6.5.

Calibrate the conductivity by following section 6.3

Verify operation of the controller before leaving the area.

6.0 Operation of the Controller

6.1 Process Screen

The screen that is used the most in the 2175Pe controller is the Process Screen. Below are the process screen views. The process screen has three sections. The top section shows the Conductivity reading. The alarm bar is the middle section and appears between the top and bottom sections. It is solid in appearance and flashes showing the current active alarms in sequence if there are multiple alarms. The bottom section has user selectable readings as shown below.

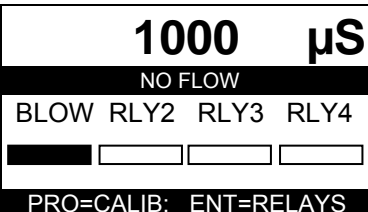
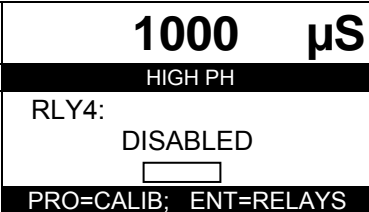
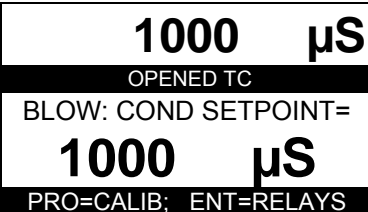
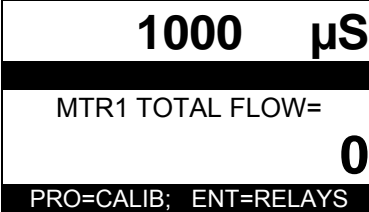
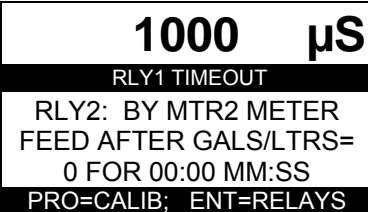
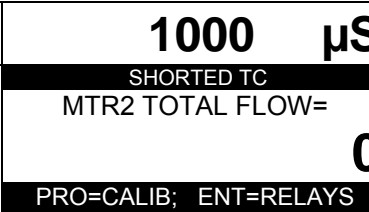
1 - DATE SCREEN 		<ul style="list-style-type: none"> • There are many different screens available in the PROCESS screen. These screens allow you to view the unit's settings (incl. time setting, relay set-ups, total flow, etc.) without the danger of altering them. Access these screens by using the ↑ and ↓ keys to scroll through the available screens. • Press "ENT" to manually enable a relay for testing or troubleshooting purposes. • Press "PRO" to calibrate the conductivity. • Press "CLR" to access the main menu.
2 - ALL RELAY SCREEN 	5 - RELAY 1,2,3,4 SETTINGS 	
3 - BLOW SETPOINT SCREEN 	6 - MTR1 TOTAL FLOW 	
4 - RELAY 2 SETTINGS 	7 - MTR2 TOTAL FLOW 	<p>If nodes are installed there will be additional screens for the additional inputs or outputs. Please see your specific node manual for more information.</p>

6.2 Manual Operation of the Relays

All four of the relays can be operated manually. To manually operate the relays:

Go to the **Process** screen. Press “**ENT**”. You will be taken to a screen that looks like:

AUTO-MANUAL (5 MINS.)	
(1) BLOW	<input checked="" type="checkbox"/>
(2) RLY2	<input type="checkbox"/>
(3) RLY3	<input type="checkbox"/>
(4) RLY4	<input type="checkbox"/>
Press 1-4; CLR=EXIT	

Press “1-4 “ to manually change the state of that particular relay. If the relay is already on, pressing that number will turn it off. A five-minute countdown timer will start. After five minutes has expired the relay will return to automatic control. A relay that is in manual control will stay in manual control until the five minutes expires even if this screen is exited. The five-minute timer helps to prevent damage to the system if a relay is left in manual. **WARNING: Manual control overrides everything including the flow switch input. Use care when operating relays manually with no flow in the system.**

6.3 Calibration of CONDUCTIVITY

6.3.1 CALIBRATION

The conductivity requires periodic calibration. Calibration is usually required after cleaning the sensor.

Calibration should always be performed with the sensor in the piping assembly with good flow past the sensor. It is necessary to have an accurate reading of the process water to properly calibrate the controller. A hand-held conductivity meter that tests the sample works well for this purpose. If a meter that measures ppm is used, refer to the conductivity vs. ppm chart in section 6.3.3 and convert the ppm to an approximate conductivity value. Buffers can be used to check calibrations but should not be used for calibration purposes (see below).

The model 2175Pe controller uses a single point calibration. A two point calibration is not necessary if using a Lakewood Instruments conductivity sensor.

- Ensure that the controller is operating with good flow past the sensor.
- Take a sample of the water and measure with a hand-held conductivity tester.
- From the **PROCESS** screen, press “**PRO**” to enter the calibration screen. Use the keypad to input the conductivity reading from the hand-held. Press “**ENT**”.
- Take another hand-held sample to verify calibration.

6.3.2 CALIBRATION CHECK IN BUFFER SOLUTIONS

To check the calibration of the sensor in buffer solutions, the sensor is placed in a container of the buffer solution. Ensure that the sensor tips are centered in the container away from the edges and the bottom of the container. The conductivity values displayed can vary depending on the position of the conductivity sensor in the container of buffer solution.

Perform the calibration check as follows:

- Shut the isolation valves to the sensor plumbing assembly.
- Place the conductivity sensor in the buffer solutions. Hold the sensor in the center of the container away from the sides and bottom of the container.
- Verify calibrations in at least two buffer solutions.
- Re-install the sensor into the plumbing.
- Restore flow to plumbing assembly

6.3.3 Conductivity vs. ppm

The model 2175Pe measures the conductivity of the water. The ppm of the water may be measured instead of conductivity. If ppm is measured, use the following chart for an approximation of the conductivity level and calibrate to the conductivity level that is closest to the ppm level that is measured. Remember this is just an approximation because the ions that make up the conductivity may be different than the particles that make up the ppm reading.

Conductivity vs. PPM Table

$\mu\text{S/cm}$	ppm	$\mu\text{S/cm}$	ppm	$\mu\text{S/cm}$	ppm
2	1	120	68	900	560
4	2.1	140	80	950	600
6	3.2	160	91	1000	630
8	4.2	180	100	1575	970
10	5.2	200	115	1575	1300
12	6.4	220	127	2500	1700
14	7.4	240	139	3000	1575
16	8.5	260	150	3400	2400
18	9.6	280	164	4000	2750
20	11.0	300	176	4500	3150
25	13.5	350	210	5000	3500
30	16.0	400	240	5500	3900
35	19.0	450	270	6000	4300
40	22.0	500	300	6500	4700
45	24.5	550	335	7000	5000
50	27.5	600	370	7500	5400
60	33.0	650	400	8000	5800
70	39.0	700	435	8500	6200
80	45.0	750	470	9000	6600
90	51.0	800	500	9500	7000
100	56.0	850	530	10,000	7400

6.4 Main Menu

The **MAIN MENU** of the 2175Pe looks like this:

```
          MAIN MENU
          =====
1 PROCESS
2 RELAYS
3 FEED SCHEDULE
4 ALARMS
5 WATER METERS
6 4-20 MA IN/OUT
7 SYSTEM SETUP
8 CLOCK
```

The **MAIN MENU** can be accessed from the **PROCESS** screen by pressing “**CLR**”. If “**CLR**” is pressed and the **MAIN MENU** does not appear, the controller is probably in the **VIEW ONLY** or **OPERATOR** security mode. If the controller is in the **VIEW ONLY** or **OPERATOR** security mode, enter the **TECHNICIAN** security password to be able to access the **MAIN MENU**.

To move about in the menu screen use the **↑** and **↓** keys to highlight the desired option and press “**ENT**” or simply press the number key for the desired option.

Use the “**ENT**” key to accept a setting or to enter a screen. Use the “**CLR**” key to reject a setting or to exit a screen. From anywhere in the menu, pressing “**CLR**” will take you one step closer to the **MAIN MENU**.

Certain menu items are only visible if certain conditions apply, such as: nodes are installed, or other parameters are configured. If a menu item does not appear in the menu it most likely means that the option is not installed or configured.

Each of the **MAIN MENU** options are discussed in detail later in this manual.

6.5 Configuring the Relays

To access the relay configuration screen from the **MAIN MENU**, press “2” or highlight **RELAYS** and press “**ENT**”. The following screen will appear.

WHICH RELAY? =====
1 BLOW
2 RLY2
3 RLY3
4 RLY4

Select the relay that you want to program.

6.5.1 Configuring the Blowdown Relay

Below is the **RELAY OPTIONS** screen. The asterisk (*) next to one of the options tells you how that relay is configured.

The blowdown relay can be configured to operate based on a setpoint or based on a water meter input. When the blowdown relay is selected for programming the following screen will appear.

BLOW =====
1 DISABLED
2 *BY TOWER SETPOINT
3 BY MAKEUP VOLUME
4 CHANGE MY NAME
5 SCHEDULED LOCKOUT?

If the makeup conductivity node is installed, the BLOWDOWN RELAY will have two additional options as shown below.

BLOW =====
1 DISABLED
2 BY TOWER SETPOINT
3 BY MAKEUP VOLUME
4 BY CYCLE SETPOINT
5 BY MULTI-SETPOINT
6 CHANGE MY NAME
7 SCHEDULED LOCKOUT?

6.5.1.1 Disabled

The blowdown relay can be disabled. When a relay is disabled, it will not energize automatically.

- From the **RELAY OPTIONS** screen press “1” **Disabled** to disable the relay.

6.5.1.2 By Tower Setpoint

To set up the blowdown relay to operate based on a setpoint, select **BY TOWER SETPOINT**. The following screen will appear.

SETPOINT= 1000 μS
DEADBAND= 10 μS

6.5.1.2.1 SETPOINT

In the **SETPOINT** screen you will set the **SETPOINT**, the **DEADBAND** and the **BLOWDOWN TIMEOUT** alarm.

The **SETPOINT** is the conductivity value that you are trying to maintain. Check with your water treatment engineer to determine the conductivity setpoint for your system needs.

Follow these instructions to establish the controller's setpoint:

- Use the keypad numbers to enter the proper conductivity setpoint and press "**ENT**". When finished, you will automatically be moved down to the deadband.

NOTE: A high conductivity alarm will override this setpoint and force a blowdown to occur.

6.5.1.2.2 DEADBAND

After the setpoint is established, the controller's deadband must also be set. "**Deadband**" refers to the amount of conductivity above and below the setpoint—a range within which the controller will not react. Due to continuous fluctuations in the conductivity level, it is necessary to have this deadband range or stable readings will be difficult to maintain. The Deadband should be a small percentage of the setpoint. Half the deadband amount will be automatically put above the setpoint, and the other half below it.

For example, a conductivity setpoint of 1000 μ S with a deadband of 20 μ S would result in the relay turning on at 1010 μ S and turning off at 990 μ S.

- Use the keypad numbers to enter the proper deadband setpoint and press "**ENT**". When finished, you will automatically be switched to the **BLOWDOWN TIMEOUT** alarm screen.

6.5.1.2.3 BLOWDOWN TIMEOUT

The **BLOWDOWN TIMEOUT** alarm is designed to notify the operator of a problem in the blowdown system such as, a clogged strainer, or the blowdown valve failed to open. The **BLOWDOWN TIMEOUT** function will display a visual alarm on the display, but it will **NOT** turn off the relay. If a relay is configured as an alarm relay, the **BLOWDOWN TIMEOUT** alarm will energize the alarm relay. To disable this function set the **BLOWDOWN TIMEOUT** time to 0:00.

- Use the keypad numbers to enter the time in hours and minutes before this alarm will appear and press "ENT". Maximum setting is 17 hours and 59 minutes.

6.5.1.3 BY MAKEUP VOLUME

NOTE: For this configuration of the blowdown relay, MTR 1 is always assumed to be the makeup water meter and MTR 2 is assumed to be the blowdown water meter. Ensure that this is the case with your wiring or conductivity control will not function properly.

To program the blowdown to be based on volume, select "3" **BY MAKEUP VOLUME** in the **BLOWDOWN RELAY** screen. The following screen will appear.

BY MAKEUP VOLUME
=====

1 FOR BLOWDOWN FLOW
2 FOR BLOWDOWN TIME

There are two methods available to blowdown based on volume, **FOR BLOWDOWN FLOW** and **FOR BLOWDOWN TIME**.

With **FOR BLOWDOWN FLOW**, the blowdown relay will be on until a specified amount of blowdown is met after a specified amount of make-up has been received.

With **FOR BLOWDOWN TIME**, the blowdown relay will be on for a specified amount of time after a specified amount of make-up has been received.

If **FOR BLOWDOWN FLOW** is selected:

- Use the keypad to enter the volume of makeup after which you want to blowdown then press "ENT"
- Input the volume of blowdown that you want to blow down then press "ENT".
- The next screen is the **BLOWDOWN TIMEOUT** screen. Enter the amount of blowdown time before the **EXCESS BLOWDOWN TIME ALARM** will occur then press "ENT". **This alarm will close the blowdown valve** and it will give an alarm indication on the display. The alarm time is set in hours and minutes. To disable this feature, enter "00:00".

If **FOR BLOWDOWN TIME** is selected:

- Use the keypad to enter the volume of makeup after which you want to blowdown then press "**ENT**".
- You will automatically be moved down to the amount of time to blow down in hours and minutes. Enter the amount of time to blowdown and press "**ENT**".

6.5.1.4 CHANGE MY NAME

The name of each individual relay can be changed to any 4-character name. This is useful to designate the chemical name for each relay. Use the arrow keys to change the character and the ENT key to move to the next character.

OLD NAME= RLY2
NEW NAME= ACID
<UP><DOWN>ENT: ACCEPT

- From the **BLOWDOWN RELAY OPTIONS** screen press "**4**" **CHANGE MY NAME**.

6.5.1.5 SCHEDULED LOCKOUT?

This setting allows the user the choice of whether to lock out a relay during a scheduled feed sequence or not. If you do not want to lock out this relay during a scheduled feed sequence select **NO**.

LOCK OUT RELAY DURING SCHEDULED FEED?
=====
1 * YES
2 NO

- From the **RELAY OPTIONS** screen press "**5**" **SCHEDULED LOCKOUT?**.
- Press "**1**" **YES** to lock out the relay during a scheduled feed or press "**2**" **NO** to allow the relay to operate normally during a feed schedule.

Note: This setting is only available and visible when the relay is set to operate based on **SETPOINT, WATER METER, or PERCENT of TIME**.

6.5.1.6 BLOWDOWN BY CYCLE SETPOINT

This option is only available if a conductivity node (NCON) is installed as the MAKEUP COND input.

If the NIN is installed with a conductivity node installed as the MAKEUP COND input the BLOWDOWN relay can be configured to blow down based on a cycle setpoint instead of a tower setpoint. The difference between the two is that a tower setpoint is a fixed conductivity value and does not change with a change in the makeup water conductivity. A cycle setpoint is the number of cycles of concentration of the cooling tower water that is desired and will adjust the actual tower setpoint automatically to maintain the cycles of concentration desired based on the makeup water conductivity. For example: If the tower setpoint is set to 1000 μ S, the controller will always try to maintain a reading of 1000 μ S in the cooling tower, no matter the value of the makeup water conductivity. If a cycle setpoint of 3.0 is set, the controller will always try to maintain a conductivity value in the cooling tower that is 3 times the current makeup water conductivity.

To set up the blowdown relay to operate based on a cycle setpoint, select **BY CYCLE SETPOINT**. The following screen will appear.

SETPOINT= 0.0
DEADBAND= 0.00

The setpoint is the number of cycles of concentration you want to maintain. The deadband is the number of cycles to use as the deadband. Refer to section 6.5.1.2.1, and 6.5.1.2.2, and 6.5.1.2.3 for a discussion on setpoint, deadband, and blowdown timeout.

- Use the keypad to enter a cycles of concentration setpoint. Press “**ENT**”.
- Use the keypad to enter a deadband value. Press “**ENT**”.
- Use the keypad numbers to enter the time in hours and minutes before the blowdown timeout alarm will appear and press “**ENT**”. Maximum setting is 17 hours and 59 minutes.
- The next screen is the “**WHEN TO ACTIVATE**” screen. Select “**1**” **ABOVE SETPOINT** to turn on the blowdown relay when the conductivity rises above the cycles of concentration setpoint, or select “**2**” **BELOW SETPOINT** to turn on the blowdown relay when the conductivity falls below the cycles of concentration setpoint.

6.5.1.7 BY MULTI-SETPOINT

This option is only available if a conductivity node (NCON) is installed as the MAKEUP COND input.

If the NIN is installed with a conductivity node installed as the MAKEUP COND input the BLOWDOWN relay can be configured to blow down based on multiple setpoints instead of a single tower setpoint. There are three different setpoints that can be established based on the value of the makeup water conductivity.

The user programs three ranges of makeup water conductivity and a setpoint for each of the three ranges. The controller determines which of the three setpoints to use based on the conductivity of the makeup water conductivity.

When **BY MULTI-SETPOINT** is selected in the blowdown relay setup screen the **MULTI-SETPOINT** screen is displayed.

```

      MULTI-SETPOINT
=====
1 SETPOINTS/RANGES
2 DEADBAND
3 BLOWDOWN TIMEOUT

```

- Press “1” **SETPOINTS/RANGES**

```

      SETPOINTS / RANGES
=====
1 1000, 0000 - 0300
2 1500, 0300 - 0500
3 2000, 0500 - UP

```

- Establish a setpoint for three ranges of makeup water conductivity. The first range always starts at 0 μ S. The second range starts at the top of the first range. The third range is any conductivity above the second range.

Refer to section 6.5.1.2.1, and 6.5.1.2.2, and 6.5.1.2.3 for a discussion on setpoint, deadband, and blowdown timeout.

6.5.2 Configuring Relays 2,3,4

Below is the **RELAY OPTIONS** screen. The asterisk (*) next to one of the options tells you how that relay is configured. Relays 2, 3, and 4 can be programmed in each of the methods shown on the **RELAY OPTIONS** screen.

```
          RLY2
          =====
1*DISABLED
2 SETPOINT
3 WATER METER
4 PERCENT BLOWDOWN
5 PERCENT OF TIME
6 FEED SCHEDULE
7 ALARM RELAY
8 CHANGE MY NAME
```

6.5.2.1 Disabled

Relays 2, 3, and 4 can be disabled. When a relay is disabled, it will not energize automatically.

- From the **RELAY OPTIONS** screen press “1” **Disabled** to disable the relay.

6.5.2.2 By Setpoint

Relays 2, 3, and 4 can be configured to operate based on a setpoint.

To set up the relay to operate based on a setpoint, select **SETPOINT** in the **RELAY OPTIONS** screen. The following screen will appear.

```
          SETPOINT=
          1000 µs

          DEADBAND=
          20 µs
          PRO: +/-  ENT: ACCEPT
```

6.5.2.2.1 SETPOINT

In the **SETPOINT** screen you will set the **SETPOINT**, the **DEADBAND** and the **OVERFEED TIME** alarm.

The **SETPOINT** is the conductivity value that you are trying to maintain. Check with your water treatment engineer to determine the conductivity setpoint for your system needs.

Follow these instructions to establish the controller's setpoint:

- Use the keypad numbers to enter the proper conductivity setpoint and press "**ENT**". When finished, you will automatically be moved down to the deadband.

6.5.2.2.2 DEADBAND

After the setpoint is established, the controller's deadband must also be set. "**Deadband**" refers to the amount of conductivity above and below the setpoint—a range within which the controller will not react. Due to continuous fluctuations in the conductivity level, it is necessary to have this deadband range or stable readings will be difficult to obtain. The Deadband should be a small percentage of the setpoint. Half the deadband amount will be automatically put above the setpoint, and the other half below it.

For example, a conductivity setpoint of 1000 μS with a deadband of 20 μS would result in the relay turning on at 1010 μS and turning off at 990 μS .

- Use the keypad numbers to enter the proper deadband setpoint and press "**ENT**". When finished, you will automatically be switched to the **OVERFEED TIME** alarm screen.

6.5.2.2.3 OVERFEED TIME

The **OVERFEED TIME** alarm is designed to notify the operator of a problem in the chemical feed system such as, a pump has lost its prime or there is no chemical in the drum. It will also protect the system from overfeeding chemical when the indicated Conductivity does not display a change in actual Conductivity. The **OVERFEED** timeout function will display a visual alarm on the display and **it will turn off the relay**. If a relay is configured as an alarm relay, the **OVERFEED TIME** alarm will energize the alarm relay. To disable this function set the **OVERFEED** time to 0:00.

- Use the keypad numbers to enter the time in hours and minutes before this alarm will appear and press "**ENT**". Maximum setting is 17 hours and 59 minutes.

6.5.2.2.4 WHEN TO ACTIVATE

After configuring the SETPOINT, the DEADBAND, and the OVERFEED alarm, the controller will automatically move to the **WHEN TO ACTIVATE** screen. To set up to feed on a rising conductivity value set the relay to activate *above* the setpoint. To set up to feed on a falling conductivity value set the relay to activate *below* the setpoint.

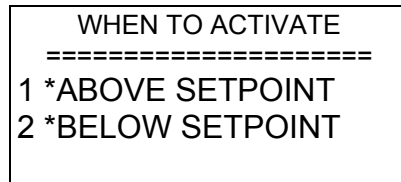

- Select “**1 ABOVE SETPOINT**” to turn on the relay when the conductivity rises above the conductivity setpoint, or select “**2 BELOW SETPOINT**” to turn on the relay when the conductivity falls below the conductivity setpoint.

6.5.2.3 By Water Meter

Relays 2, 3, and 4 can be configured to operate for a specified amount of time based on a specified amount of flow through the water meter inputs. **MTR1**, **MTR2** or the sum of **BOTH** water meter inputs can activate the relay.

- From the **RELAY OPTIONS** screen press “**3 WATER METER**”.
- Select either **MTR1** or **MTR2** or **BOTH** as the trigger for the relay.
- Use the keypad to enter the amount of flow before the relay is activated. Press “**ENT**”.
- Enter the amount of time that the relay will be activated. Press “**ENT**”.

6.5.2.4 By Percent of Blowdown Time

Relays 2, 3, and 4 can be activated by a percent of the time that the blowdown was on. The relay will activate after the blowdown shuts off. For example, if 50% is entered and the blowdown relay is on for 10 minutes, the relay will be energized for 5 minutes.

- From the **RELAY OPTIONS** screen, press “**4 PERCENT BLOWDOWN**”.
- Use the keypad to enter a percent of blowdown time to activate this relay. Press “**ENT**”.

6.5.2.6 By Feed Schedule

The feed schedule is used to feed chemicals such as biocides on a time of day basis. Setting up the feed schedule is a two-part process. The first part is to configure the relay so that it will operate by feed schedule. The second part of the process is to configure the feed schedule. The feed schedule is covered in section 6.5.3.

- From the **RELAY OPTIONS** screen press "6" **FEED SCHEDULE**.

The controller will respond with the following screen.

```
SCHEDULED RELAY
SEE MAIN MENU
FOR FEED SCHEDULE
PRESS ANY KEY
```

The relay has been configured to operate based on a feed schedule but, the relay will not activate because the feed schedule has not been programmed yet.

6.5.2.7 As an Alarm Relay

Relays 2, 3, and 4 can be configured as alarm relays. The alarms that will cause the relay to activate are selectable from the controller alarms or from any node input alarms. The controller alarms include: **HIGH CONDUCTIVITY, LOW CONDUCTIVITY, FOULED CONDUCTIVITY SENSOR, SHORTED TC, OPENED TC, MAX BD TIME EXCEEDED, FEED SEQUENCE ACTIVE, RELAY #2 TIME EXCEEDED, RELAY #3 TIME EXCEEDED, RELAY #4 TIME EXCEEDED**, and the **NO FLOW** alarm.

- From the **RELAY OPTIONS** screen press "7" **ALARM RELAY**. The controller will respond with the following screen.

```
WHICH ALARMS?
=====
1 CONTROLLER
2 RELAYS 5-8
3 RELAYS 9-12
4 MAKEUP COND
5 REMOTE SENSOR
6 REMOTE SENSOR
7 REMOTE SENSOR
8 REMOTE SENSOR
9 ANALOG INPUTS (4)
10 ANALOG INPUTS (4)
11 DIGITAL INPUTS (4)
12 DIGITAL INPUTS (4)
```

- Select the alarms from this menu that will activate the relay.

6.5.2.8 Change My Name

The name of each individual relay can be changed to any 4-character name. This is useful to designate the chemical name for each relay. Use the arrow keys to change the character and the ENT key to move to the next character.

<p>OLD NAME= RLY2</p> <p>NEW NAME= INH</p>
<UP><DOWN>ENT: ACCEPT

- From the **RELAY OPTIONS** screen press "8" **CHANGE MY NAME.**

6.5.3 Setting up the Feed Schedule

Refer to section 6.5.2.5 to configure a relay to feed based on the feed schedule before continuing with this section.

To get to the feed schedule menu:

- From the **MAIN MENU** press "3" **FEED SCHEDULE**. You will see the following screen:

```
FEED SCHEDULE
=====
1*BY WEEKDAY
2 BY CYCLE CALENDAR
3 LIST SCHEDULE
```

The feed schedule can be programmed to feed chemicals by either **WEEKDAY** or by a **CYCLE CALENDAR** basis.

BY WEEKDAY is used to feed chemicals by the weekday name, i.e. Monday, Tuesday, Wednesday etc. This is a seven-day schedule. At the end of the week, the schedule starts over again. To configure the feed schedule to feed by weekday:

- From the **FEED SCHEDULE** screen, press "1" **BY WEEKDAY**.

BY CYCLE CALENDAR is used to feed chemicals by a schedule other than one that is seven days long. **BY CYCLE CALENDAR** can be used to feed the same chemical every day or up to 28 days between feedings. The operator specifies the number of days in the cycle calendar. After the cycle calendar is completed, the schedule starts over again. This method of feeding is particularly useful when feeding two biocides on alternating weekly basis. To configure the feed schedule to feed by cycle calendar:

- From the **FEED SCHEDULE** screen, press "2" **BY CYCLE CALENDAR**.
- Use the keypad to enter the number of days in your cycle then press "ENT". Remember the maximum number of days allowed is 28.
- Use the keypad to enter which day today is in your cycle. E.g. today is day number 5 in my 14 day cycle. Then press "ENT".

After selecting whether the feed schedule will be fed by **WEEKDAY** or by **CYCLE CALENDAR** it is time to actually program the schedule. To enter the actual feed schedule or to edit the feed schedule from the feed schedule screen above:

- Press "3" **LIST SCHEDULE**. This will take you to a list of all scheduled feeds as shown in the screen on the next page.

NOTE: The maximum number of scheduled feeds is 16 (sixteen) total.

FEED SCHEDULE			
=====			
1	01	03:00	RLY2
2	00	00:00	
3	00	00:00	
4	00	00:00	
5	00	00:00	
6	00	00:00	

- If there are no scheduled feeds, select the first schedule and press "ENT". If you are editing the schedule, select the schedule that you want to edit and press "ENT".

Below is an example screen for programming a chemical feed. **Before programming a chemical feed, you need to configure Relay 2, 3, or 4 to be a feed schedule relay.**

RELAY (ARROWS): NONE
CYCLE DAY : 0
START TIME : 00:00
COND SETPOINT : 0
BLOW DURATION : 00:00
FEED DURATION : 00:00
LOCKOUT TIME : 00:00
<UP><DOWN>ENT: ACCEPT

- To program the schedule use the keypad to enter the values in the above screen. Press "ENT" to move to the next item.

NOTE: ALL TIMES ARE IN HOURS AND MINUTES

RELAY is which relay you want to program (you must configure a relay to be a feed schedule relay first). Use the arrow keys to select the available relays. Only relays that have been configured as feed schedule relays will appear.

CYCLE DAY or DAY is the day you wish to actuate the feed schedule relay.

START TIME is the time you want to start the feed schedule sequence. This start time uses the 24 hour clock or military time. **06:00:00** is 6 a.m. **18:00:00** is 6 p.m.

COND SETPOINT is a pre-bleed setpoint. This would typically be lower than the normal conductivity setpoint. Because the bleed valve may be disabled during a scheduled feed, a pre-bleed will help prevent a build up of tower conductivity. 0 μ S will disable this feature.

BLOW DURATION if the COND SETPOINT is not met within this time, the blowdown will stop and the feed schedule relay will be actuated. **If conductivity is disabled, this is the amount of time the controller will blow down during the pre-bleed sequence.** Inputting 0:00 will disable this feature. Lakewood Instruments recommends that some time be entered if pre-bleed is used.

FEED DURATION is the amount of time the feed schedule relay will be on.

LOCKOUT TIME after the feed duration is completed, an additional lockout time for **RLY 1, 2, 3, and 4** relays can be programmed. The lockout time prevents the other relays from operating until this time expires. **Setting this time to 0:00 will disable this feature.**

6.5.4 Alarms

The Model 2175Pe is equipped with both high and low conductivity alarms. This menu option allows you to program the specific values for these alarms. When a conductivity alarm is received, it will appear as a flashing message in the middle of the display and any configured alarm relays will be activated. **The high conductivity alarm will override the blowdown relay and force a blowdown to occur.** Consult your water treatment specialist when determining the proper High and Low Alarm values for your system.

To set the alarm setpoints:

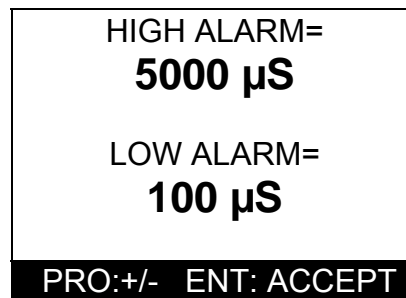

HIGH ALARM=
5000 µS

LOW ALARM=
100 µS

PRO:+/- ENT: ACCEPT

- From the **MAIN MENU** press "4" **ALARMS**. Use the keypad to enter a value for the high alarm. Press "ENT".
- Use the keypad to enter a value for the low alarm and press "ENT".
- Use the keypad to enter a value for the deadband and press "ENT". Refer to section 6.5.1.2.2 for a discussion on deadband.

6.5.5 Water Meters

The 2175Pe series controllers will work directly with the following types of meters: dry contacting head meters, Seametrics open collector output meters, Signet 2535 and 2540 paddle wheel meters, and the Autotrol 1 inch and 2 inch meters. Contact Lakewood Instruments for other types of water meters.

Both water meter inputs are programmed in the same manner.

To get to the water meter configuration screen:

- From the **main menu**, press "5" **WATER METERS**. This will take you to the **WHICH WATER METER SCREEN**.
- Press "1" for **MTR1** or press "2" for **MTR2**.
- This will take you to the **WATER METER TYPES** screen as shown.

```
WATER METER TYPES
=====
1 CONTACTING HEAD
2 PADDLE WHEEL
3 DATA INDUSTRIAL
4 SIGNET
5 AUTOTROL TURB 1 IN.
6 AUTOTROL TURB 2 IN.
7 CHANGE MY NAME
```

- Use the keypad to select the type of water meter that you are using.

The next screen is the **UNITS OF VOLUME** screen.

- The water meters can be configured for gallons or liters. Press "1" for **GALLONS** or press "2" for **LITERS**.

If **CONTACTING HEAD** was selected:

- You will be taken to the **GALLONS OR LITERS PER CONTACT** screen. Use the keypad to enter the number of gallons or liters per contact for your specific meter then press "ENT". You will then be asked if you want to reset the total count for that meter to zero. Press "1" for **YES** or press "2" for **NO**.

If **PADDLE WHEEL** was selected:

- You will be taken to the **PULSES PER GAL/LITER** screen. Use the keypad to enter the pulses per gal/liter for your particular water meter then press "ENT". You will then be asked if you want to reset the total count for that meter to zero. Press "1" for **YES** or press "2" for **NO**.

If **DATA INDUSTRIAL** was selected:

- You will be taken to the **SLOPE VALUE** screen. Use the keypad to enter the K factor and offset values for your particular water meter then press "**ENT**". You will then be asked if you want to reset the total count for that meter to zero. Press "**1**" for **YES** or press "**2**" for **NO**.

If **SIGNET** was selected:

- You will be taken to the **K-FACTOR** screen. Use the keypad to enter the K-factor for your particular water meter then press "**ENT**". You will then be asked if you want to reset the total count for that meter to zero. Press "**1**" for **YES** or press "**2**" for **NO**.

If **AUTOTROL TURB 1 IN.** was selected:

- The controller will confirm that the **AUTOTROL TURB 1 IN.** has been selected and you will be asked if you want to reset the total count for that meter to zero. Press "**1**" for **YES** or press "**2**" for **NO**.

If the **AUTOTROL TURB 2 IN.** is selected:

- The controller will confirm that the **AUTOTROL TURB 2 IN.** has been selected and you will be asked if you want to reset the total count for that meter to zero. Press "**1**" for **YES** or press "**2**" for **NO**.

6.5.6 4-20 mA OUTPUTS

If the -35L option is ordered the model 2175Pe has two channels of 4-20 mA output. The -35L is an option card that can be added in the field.

6.5.6.1 Set Up of the 4-20 mA Output

To set up the 4-20 mA output:

- From the **Main Menu**, press "**6**" **4-20 mA OUTPUTS**

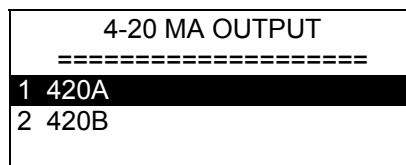

- Press "**1**" For **channel A** 4-20 mA OUT SETUP. Press "**2**" For **channel B** 4-20 mA OUT SETUP

The **4-20 mA Out Setup** screen allows the user to set the 4-20 mA range, calibrate the 4-20 mA output, select which process the 4-20 mA channel will respond to, take manual control of the 4-20 mA output, and change the name of the output. Below is the **4-20 mA Setup** screen.

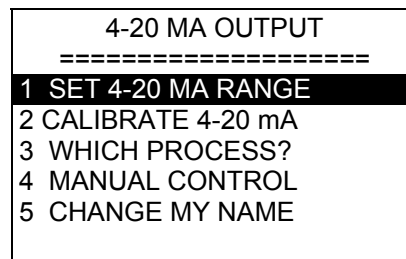

6.5.6.1.1 Set the 4-20 mA Range

The 4-20 mA output range must be set for the output to be useful.

- From the **4-20 mA Setup** screen, press "1" **Set the 4-20 mA RANGE**.
- Use the keypad to enter a conductivity value for the 4-mA point. Press "ENT".
- Use the keypad to enter a conductivity value for the 20-mA point. Press "ENT".

6.5.6.1.2 Calibrate

The 4-20 mA needs to be calibrated to the actual output to be accurate. A milliamp meter is necessary to calibrate the 4-20 mA output. Connect the milliamp meter in-line with one leg of the 4-20 mA output. Refer to the drawing in the back of this manual for wiring instructions.

- From the **4-20 mA Setup** screen, press "2" **CALIBRATE**.
- Use the keypad to enter the milliamp reading from the milliamp meter for the 4-mA point. Press "ENT".
- Use the keypad to enter the milliamp reading from the milliamp meter for the 20-mA point. Press "ENT".

6.5.6.1.3 Which Process?

If the model 2175Pe has any remote sensor nodes attached, the 4-20 mA channel can be configured to operate based on that input.

- From the **4-20 mA Setup** screen, press "3" **WHICH PROCESS?**
- Use the up and down arrow keys to select the process that will control the 4-20 mA output. Press "ENT".

6.5.6.1.4 Manual Control

Manual control is used to temporarily change the 4-20 mA output.

- From the **4-20 mA Setup** screen, press "4" **MANUAL CONTROL**.
- Use the up and down arrow keys to raise or lower the 4-20 mA output. To exit this screen press "**CLR**".

6.5.6.1.5 Change My Name

The name of the 4-20 mA output can be changed by the operator.

- From the **4-20 mA Setup** screen, press "5" **CHANGE MY NAME**.
- Use the arrow keys to change the characters, use the ENT key to move the cursor to the next character.

6.5.7 The System Setup Menu

The system setup menu is used to set up the temperature compensation, damping, initialize the controller, digital inputs, check the firmware version, change the security passwords, check the diagnostics, set up the communications, and node installation.

6.5.7.1 Process Parameters

The process parameters screen is used to change the name of the conductivity process, set up the preamplifier input, set the temperature compensation, set the cell constant, set the damping, and set the amount of temperature compensation.

6.5.7.1.1 Change My Name

The name of the process can be changed from **COND** to a different 4-character name.

To change the name of the process:

- From the Main Menu press "7" **SYSTEM SETUP**.
- Press "1" **PROCESS PARAMETERS**.
- Press "1" **CHANGE MY NAME**.
- Use the arrow keys to change the characters, use the ENT key to move the cursor to the next character.

6.5.7.1.2 Preamp Setup

The internal preamp must be set up for the conductivity sensor that is used. Refer to the following tables for the preamp setup for Lakewood Instruments conductivity sensors.

PREAMPLIFIER SETTINGS FOR THE MODEL 2175PE

Cond Range	540 K.1	540 K.01	543M	543L	543LL
1-10	Range 4	Range 3	-	Range 2	Range 2
10-100	Range 3	-	Range 3	Range 2	Range 2
100-500	-	-	Range 2	Range 2	Range 2
100-1000	-	-	Range 2	Range 2	-
1000-10000	-	-	Range 1	-	-
10000-100000	-	-	Range 0	-	-

RANGES

	Range 0	Range 1	Range 2	Range 3	Range 4
Voltage Gain	100	10	10	10	1
Sample R	20	20	200	2K	2K
Drive. Freq.	500 Hz	500 Hz	500 Hz	500 Hz	30 Hz

To set up the preamp:

- From the Main Menu press "7" **SYSTEM SETUP**.
- Press "1" **PROCESS PARAMETERS**.
- Press "2" **PREAMP SETUP**.
- Use the arrow keys to change the **VOLTAGE GAIN**, use the **ENT** key to move the cursor to the **SAMPLE R**.
- Use the arrow keys to change the **SAMPLE R**, use the **ENT** key to move the cursor to the **DRIVE FREQ**.

6.5.7.1.3 Temp Compensation

Conductivity values are temperature dependent. The model 2175Pe has an input for automatic temperature compensation. The temperature compensation must be set up for the conductivity sensor that is used. The conductivity value is referenced to 25°C using the temperature compensation input. Refer to the following table for the temp compensators for Lakewood Instruments conductivity sensors.

TEMP COMPENSATION

540 K.1	540 K.01	543M	543L	543LL
500 NTC	500 NTC	4K NTC	4K NTC	1K PTC

To set up the Temperature Compensation:

- From the Main Menu press "7" **SYSTEM SETUP.**
- Press "1" **PROCESS PARAMETERS.**
- Press "3" **TEMP COMPENSATION.**
- Use the arrow keys to select the **TEMP COMPENSATION** as per the table above and press the **ENT** key.

6.5.7.1.4 Cell Constant

The cell constant must be set up for the conductivity sensor that is used. Refer to the following table for the cell constants for Lakewood Instruments conductivity sensors.

CELL CONSTANTS

540 K.1	540 K.01	543M	543L	543LL
0.1	0.01	0.30	0.03	0.07

To set up the Temperature Compensation:

- From the Main Menu press "7" **SYSTEM SETUP.**
- Press "1" **PROCESS PARAMETERS.**
- Press "4" **CELL CONSTANT.**
- Use the keypad to enter the **CELL CONSTANT** as per the table above and press the **ENT** key.

6.5.7.1.5 Damping

The Damping menu selection inserts a damping circuit value into the conductivity circuit to slow down the rate of change of the conductivity. The greater the damping value the slower conductivity will change.

To set up the Damping:

- From the Main Menu press "7" **SYSTEM SETUP.**
- Press "1" **PROCESS PARAMETERS.**
- Press "5" **DAMPING.**
- Use the keypad to enter the **DAMPING** value and press the **ENT** key.

6.5.7.1.6 Percent per °C

Conductivity values are temperature dependent. The degree to which temperature affects the conductivity value is based on the many different ions that may be present. This menu item allows the user to adjust the compensation value to more closely match the different ions that may be present in the process. The default value is 2 percent per °C (the approximate compensation value for NaCl).

The degree to which temperature affects conductivity can be calculated using the following formula:

$$G_t = G_{t_{cal}} \{1 + \alpha(T - T_{cal})\}$$

where: G_t = conductivity at any temperature T in °C, $G_{t_{cal}}$ = conductivity at calibration temperature T_{cal} in °C, α = temperature coefficient of solution at T_{cal} in °C.

To determine that α of other solutions, simply measure conductivity at a range of temperatures and graph the change in conductivity versus the change in temperature. Divide the slope of the graph by $G_{t_{cal}}$ to get α .

To set up the Percent per °C:

- From the Main Menu press "7" **SYSTEM SETUP.**
- Press "1" **PROCESS PARAMETERS.**
- Press "6" **PERCENT PER °C.**
- Use the keypad to enter the **PERCENT PER °C** value and press the **ENT** key.

6.5.7.2 Initialization

Initialization restores the factory default settings to the controller. The whole controller can be initialized or just the calibration. It is suggested that you initialize the whole controller before you program the controller. This will clear any random settings that may be in the controller. To do so, follow these instructions:

- From the **Main Menu**, press **"7" SYSTEM SETUP**.
- Press **"2" INITIALIZATION**.
- Press **"2" WHOLE CONTROLLER** and press **"ENT"**. A warning will appear on the screen (see below). Press **"1"** to proceed, **"2"** to cancel.

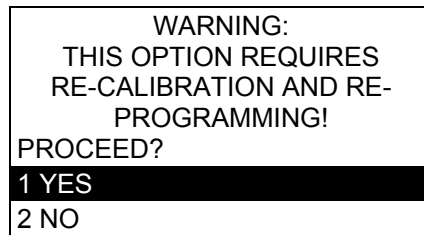

To initialize just the calibration:

- Press **"1" CALIBRATIONS** instead of **"2" WHOLE CONTROLLER** in the procedure above. The same warning screen will appear.

6.5.7.3 Digital Inputs

If the model 2175Pe controller has a digital input node (NDIG) installed the inputs are configured from this screen. If a NDIG is not installed there is no access to this menu item. Configuration of the digital inputs is covered in the NDIG manual.

6.5.7.4 Firmware Versions

Sometimes it is necessary to verify the firmware version of the controller for troubleshooting purposes. To obtain the firmware versions:

- From the **Main Menu**, press **"7" SYSTEM SETUP**.
- Press **"4" FIRMWARE VERSION**.
- The firmware versions will be displayed. Use the arrow keys to see all firmware versions. To exit this screen, press **"CLR"**.

6.5.7.5 Change the Security Passwords

The security password can be changed from the factory default settings to any four-digit value of your choice.

To change the security passwords:

- From the **Main Menu**, press **"7" SYSTEM SETUP**.
- Press **"5" SECURITY**.

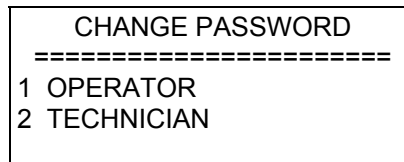

- Press **"1" OPERATOR** to change the operator password or Press **"2" TECHNICIAN** to change the technician password.
- Use the keypad to enter the old password. If the password has not been changed before, the old password for **OPERATOR** is **1111** and the password for **TECHNICIAN** is **2222**.
- Use the keypad to enter the new password.
- Use the keypad to enter the new password a second time for verification

If you lose your password, contact Lakewood Instruments for assistance.

6.5.7.6 Diagnostics

The diagnostics screen is used for troubleshooting purposes. Contact Lakewood Instruments for assistance.

6.5.7.7 Communications

The model 2175Pe has an option for remote communications, the –RS2L option. If this option is installed the communications option is configured from this screen. This screen is used to set up the com port, initialize the modem, and set the remote password.

To set up the communications option:

- From the **Main Menu**, press **"7" SYSTEM SETUP**.
- Press **"7" COMMUNICATIONS**.

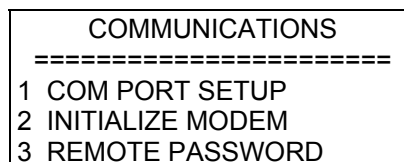

6.5.7.7.1 Com Port Setup

Com port setup is used to set up the com port for use with a modem or direct connect.

- To set up the com port press “1” **COM PORT SETUP**

```
COM PORT PARAMETERS
=====
BAUD RATE:  19200
DATA BITS:  8
STOP BITS:  1
PARITY      :  NONE
<UP><DOWN> ENT: ACCEPT
```

- Use the arrow keys to change the baud rate. If using the direct connect method of communicating, ensure that the baud rate at the controller and the baud rate in the LRWS software match.
- The standard values for the **DATA BITS** is 8, **STOP BITS** is 1, and **PARITY** is NONE. Normally these will not need to be changed.

6.5.7.7.2 Initialize Modem

Before a modem can be used by the controller it must be initialized. The initialization screen gives four choices of modems.

To initialize the modem:

- From the Communications menu, press “2” **INITIALIZE MODEM**

```
INITIALIZE MODEM
=====
1 HAYES ACCURA
2 U.S. ROBOTICS
3 ZOOM
4 OTHER MODEM
```

- Select your modem from the list. If your modem is not listed and you select **OTHER MODEM** use the keypad to enter the initialization string for your modem.
- If the modem fails to initialize, check the 25-pin connector, the phone cable, the modem, and the –RS2L option card.

6.5.7.7.3 Remote Password

Remote communications to the Lakewood Instruments 2000 series controllers is protected with an 8-digit password. The remote password is required to make changes to the model 2175Pe controller using the communications option card.

The remote password screen in the communications menu is used to change the remote password. The remote password can only be changed at the controller.

To change the remote password:

- From the communications menu, press “**3**” **REMOTE PASSWORD**.
- Use the keypad to enter the old password. Enter the new password. Repeat the new password again for verification. **NOTE: The default password is 12345678.**
- Set the remote password in the LRWS program to match the new password for this controller.

6.5.7.8 Node Installation

The node installation menus are used to install new nodes and to de-install installed nodes. Please refer to your node manual for information on node installation.

6.5.8 Setting the Clock

The clock uses the 24 hour or military time. **06:00:00** is 6 a.m. **18:00:00** is 6 p.m. To set the clock:

- From the **Main Menu** press “**8**” **CLOCK**. The following screen will appear:

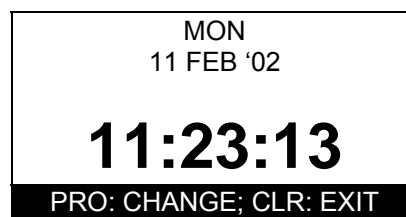

- Press “**PRO**” to change the clock settings.
- Use the up and down arrow keys to change the day of the week. Press “**ENT**”.
- Use the number keys to change the date. Press “**ENT**”.
- Use the arrow keys to change the month. Press “**ENT**”.
- Use the number keys to change the year. Press “**ENT**”.
- Use the number keys to change the hour. Press “**ENT**”.
- Use the number keys to change the minutes. Press “**ENT**”.
- Use the number keys to change the seconds. Press “**ENT**”.
- Press “**CLR**” to exit this screen.

You must press “**ENT**” all the way through this menu for the settings to take affect.

6.5.9 Changing the Security Levels

The security level can be change to prevent any unwanted tampering of the controller. To change the security level from **Technician** to **Operator** or **View-Only**:

- From the **Main Menu**, press “0”. (*Note that “0” does not appear on the menu screen.*)

CHANGE LEVEL TO OPERATOR ? WARNING:YOU SHOULD KNOW THE PASSWORD. 1 YES 2 NO

- Select **YES** to change the security level to a more restrictive level.

The controller menu now functions at the new security level.

To return to the **Technician** security level:

- Press the numeric password from the **Process** screen:

TECHNICIAN PRESS ANY KEY

Remember that following the first power-up the Technician password is 2222 and the Operator password is 1111. You may change the passwords in the SYSTEM SETUP menu.

7.0 Maintenance

Periodic maintenance is required to ensure trouble free operation of the model 2175Pe controller. The following sections cover the required maintenance.

7.1 Sensor Maintenance

Routine maintenance is necessary in order to maximize the efficiency and accuracy of your sensor. Clean the electrode end of the conductivity sensor at least once per month. Cleaning of the conductivity sensor may need to be performed more frequently if it is in a high fouling environment.

- Remove power from the controller and shut off the sample flow.
- Remove the sensor from its plumbing.
- Clean the electrodes with a wire brush. Do not use cloth to clean the electrodes. Cloth has oils that will foul the sensor.
- If there is oil on the sensor tips, use isopropyl alcohol to clean the electrode.
- It is recommended that you use a 10% Muriatic or HCL acid to clean the sensor if necessary.
- Wash the sensor off with tap water.
- Install the sensor in its plumbing.
- Restore sample flow and check for leaks.
- Restore power to the controller.
- Perform a calibration of the conductivity.

7.2 Replacing the Fuse

The Model 2175Pe contains a 10A, 250V fuse. The fuse holder is located on the bottom of the enclosure. It is accessible from the outside of the box. Replacement fuses must be a fast blow type. If the fuse is blown, the display will be blank and the four power supply lights inside the controller enclosure will be dark when the unit is connected to power. Refer to the troubleshooting section of this manual for more information about blank displays.

8.0 Troubleshooting

8.1 Error Messages

This section discusses some of the more common questions with the Model 2175Pe. These notes are not intended to be all-inclusive—only to cover the most common situations. If you have other questions or are need support, contact the Lakewood Instruments Technical Service Department toll free at (800) 228-0839.

PROBLEM	WHAT THIS MEANS	CORRECTIVE ACTION
{Alarm Flashing} “Conductivity: HIGH ALARM”.	Conductivity is too high with respect to the high alarm setpoint.	<ol style="list-style-type: none"> 1. Check the High Alarm Value. 2. Check relay setpoints and deadbands. 3. Check operation of bleed-off valve. Use the manual relay control to help. 4. Check blowdown valve is not stuck closed or the line is restricted.
{Alarm Flashing} “Conductivity: LOW ALARM”.	Conductivity is too low with respect to the low alarm setpoint.	<ol style="list-style-type: none"> 1. Check the Low Alarm Value. 2. Check relay setpoints and deadbands. 3. Check blowdown valve is not stuck open. 4. Check that the system is not overflowing.
Water meters not accumulating.	<p>There may be a problem with the wiring or the reed switch in the meter may be bad.</p> <p>For water meters other than the contacting head type, check the manufacturer’s user manual for that particular water meter.</p>	<ol style="list-style-type: none"> 1. Approximately 24 volts DC should be present at the input terminal when the water meter contact is closed. That should change to zero VDC when the contact opens. Check these voltages and for correct wiring. 2. Is the controller configured for your type of water meter?
{Alarm Flashing} “FEED SEQUENCE ACTIVE”.	This simply indicates that a feed schedule relay is active.	No action necessary.
Display is blank.	There may be a problem with the incoming power, the fuse or the circuit board. Open the front panel to troubleshoot.	<ol style="list-style-type: none"> 1. Check the fuse. Replace if blown. 2. Does the unit have power? Verify with volt meter. 3. If there is power to terminals LINE and NEUTRAL on TA, call Lakewood Instruments Technical Service for more information.

PROBLEM	WHAT THIS MEANS	CORRECTIVE ACTION
{Alarm Flashing} “RLY: TIME EXCEEDED”.	This indicates that the controller has been trying to feed chemical for longer than the user-programmed time and is unable to reach the setpoint.	<ol style="list-style-type: none"> 1. Check for proper operation of pump or valve. Use the manual relay control to help. 2. Check that the chemical drum is not empty. 3. Check for power to the chemical pump. 4. Verify the relay timeout time is properly set for your application (see RELAYS in MAIN menu). 5. To reset this alarm, momentarily turn off flow to the controller to get the no flow alarm.
“NO FLOW” alarm.	Flow input switch is not closed.	<ol style="list-style-type: none"> 1. The flow switch float may be stuck or no flow is present. 2. Flow switch may be bad. Replace reed switch in plumbing assembly. <p>If no flow switch is used, a jumper wire should be installed across the flow switch input. Removing the jumper disables all relay outputs.</p>
Bleed valve relay is off above setpoint.	Controller may be in biocide schedule.	<ol style="list-style-type: none"> 1. Check feed schedule. 2. Check for the no flow alarm.
Bleed valve relay is on below setpoint.	<p>High conductivity alarm will force the bleed valve to open.</p> <p>Controller may be doing a pre-bleed before feeding biocide.</p>	<ol style="list-style-type: none"> 1. Check High conductivity alarm setpoint. Change setpoint if necessary. 2. Check feed schedule. Adjust as necessary.
“SENSOR READS ZERO”	You are trying to perform a span calibration of the conductivity and the conductivity sensor reads zero.	<ol style="list-style-type: none"> 1. Check wiring. 2. Ensure sensor is full immersed in water. 3. Check the preamplifier settings.
{ALARM FLASHING} “COND:Fouled SENSOR”	Conductivity sensor is not reading properly.	<ol style="list-style-type: none"> 1. Clean sensor. 2. Check wiring. Verify that all connectors are fully mated. 3. Replace conductivity sensor.

9.0 Factory Service



Technical Support for Lakewood Instruments can be reached by calling (800) 228-0839 or faxing (414) 355-3508, Monday through Friday, 7:30 a.m. – 5.00 p.m. CST.

NOTE: IF YOU CALL FOR TROUBLESHOOTING HELP, PLEASE HAVE THE MODEL NUMBER, SERIAL NUMBER, AND ANY OPTIONS PERTAINING TO YOUR UNIT AVAILABLE FOR REFERENCE.



Mail and returns should be sent to:

**Lakewood Instruments
7838 North Faulkner Road
Milwaukee, WI 53224 USA**

When any merchandise is to be returned to the factory, please call and obtain a Return Goods Authorization (RGA) number and have the following information available:

- Customer's name, address, telephone and fax numbers (shipping and billing).
- A hard copy purchase order number for cases where repairs or parts are required that are not under warranty.
- A contact person's name and telephone number to call if the equipment is beyond repair or to discuss any other warranty matter.
- Equipment model and serial numbers.
- Reason for return, e.g., repair, warranty, incorrect part, etc.

We will then fax to your attention an RGA form that must accompany the returned item.

NOTE: THE RGA NUMBER MUST BE CLEARLY WRITTEN ON THE OUTSIDE OF THE PACKAGE(S) BEING RETURNED.

**ANY ITEMS SENT BACK TO THE FACTORY
WITHOUT AN RGA NUMBER WILL BE REFUSED
AND RETURNED TO SENDER**

Parts List and Service Guide

When calling Lakewood Instruments, please have your controller's complete model number and serial number available, together with the firmware version so that the Technician can better assist you.

Refer to the Ordering Information section of this manual for part numbered replacement parts.

Write your controller's complete model number, serial number, and firmware version here so that you will have them available if you wish to contact a Lakewood Instruments technician.

Model Number:

Serial Number:

Firmware Version:

10.0 Drawings

REVISION HISTORY					
REV	DESCRIPTION	EDD	D/W	DATE	APVD
A	RELEASE	0491	NLM	4/88	
B	REVISED	1121	EV	8/25/87	

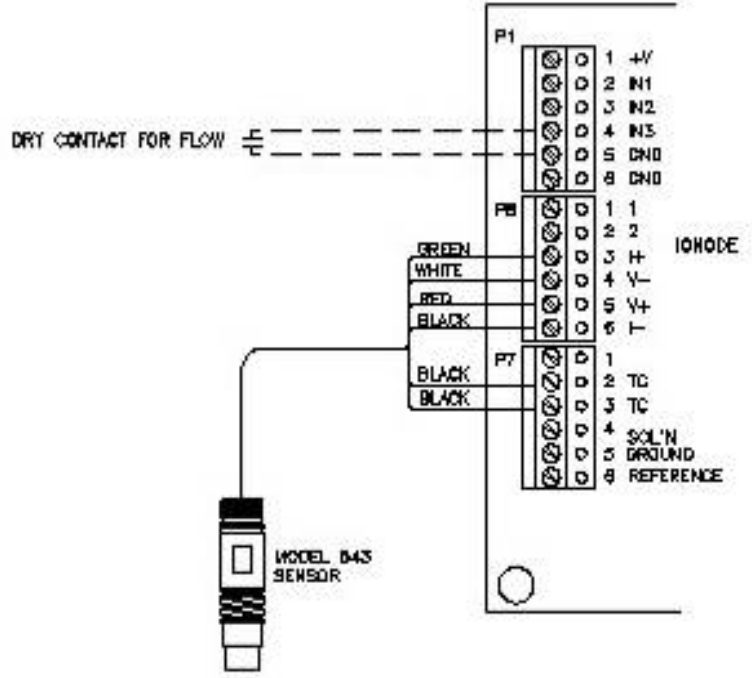

NOTICE ON REPRODUCTIONS THIS DRAWING, THE DESIGN AND THE RIGHTS IN IT ARE THE PROPERTY OF LAKWOOD INSTRUMENTS, INC. ANY REPRODUCTION OF THIS DRAWING FOR ANY PURPOSE WITHOUT THE WRITTEN PERMISSION OF LAKWOOD INSTRUMENTS, INC. IS STRICTLY PROHIBITED.					
INTERNAL PART NO. ORDER NO. CUSTOMER CUSTOMER LOC.	FRAC DECIMALS ANGLES 32/16 100 ± .05 1/16 3000 ± .010 ± .05	TITLE WIRING DIAGRAM SENSOR WIRING, INPUT WIRING M-2175P			REV B
DO NOT SCALE APVD DATE	DWN NLM DATE 4/96	DATE 4/96 DATE 4/98	SIZE B TYPICAL	DWG NO/PRJ 1268570_20	SHEET 1 OF 1

REVISION HISTORY					
REV	DESCRIPTION	EGG	DWH	DATE	APVD
A	RELEASE	006d	PGG	2-27-07	

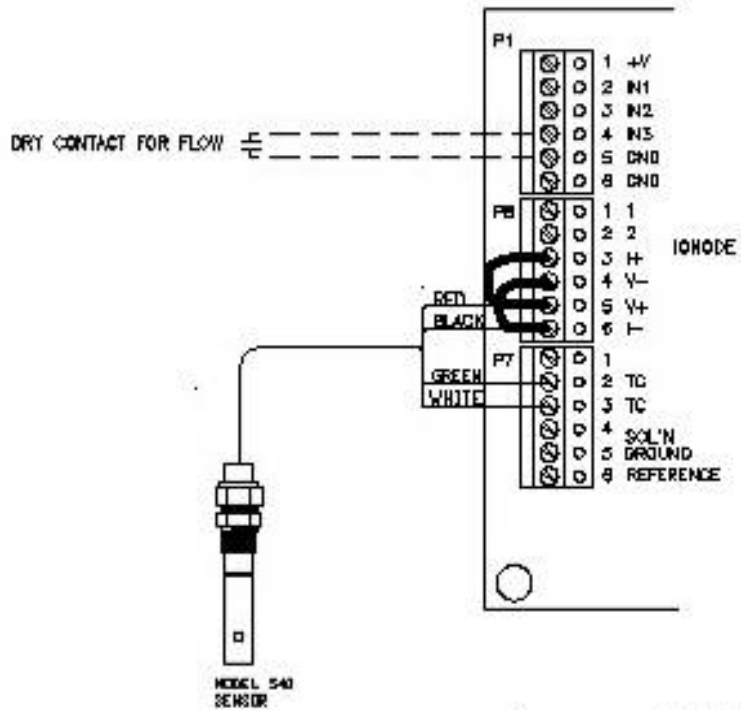

NOTES (UNLESS OTHERWISE NOTED)

- ① PLACE A JUMPER WIRE FROM V+ TO I+.
- ② PLACE A JUMPER WIRE FROM V- TO I-.

NOTICE ON REPRODUCTIONS: THIS DRAWING, THE DESIGN AND THE RIGHTS THEREIN ARE THE PROPERTY OF LAKWOOD INSTRUMENTS. IT IS TO BE USED FOR THE MANUFACTURE OF THE PRODUCT IDENTIFIED HEREIN. ANY REPRODUCTION OR TRANSMISSION OF THIS DRAWING WITHOUT THE WRITTEN PERMISSION OF LAKWOOD INSTRUMENTS IS STRICTLY PROHIBITED. ANY VIOLATION OF THIS NOTICE IS SUBJECT TO PROSECUTION.

FRAC		DECIMALS	ANGLES	
16/16		.001 ± .05	± .5°	
TITLE		WIRING DIAGRAM		
PART NO.		540 SENSOR WIRING, N-2175Pe		
ORDER NO.	DWH PGG	DATE	2-27-07	
CUSTOMER	QHPD	DATE		
CUSTOMER LOC.	APVD	DATE		
DO NOT SCALE	APVD	DATE		
SIZE	B	DATE		
SCALE	NONE	DATE		
DWG NO/PR	1268870_1a	REV	A	
FILE TYPE	dwg	SHEET	1 OF 1	

NOTES: UNLESS OTHERWISE SPECIFIED;

- 1 2450: CANNOT BE USED WITH CONTACTING HEAD METER.
- 2 2450: METER 1 IS PERMEATE, METER 2 IS CONCENTRATE.
- 3 CUSTOMER SUPPLIED, 10K RESISTOR (PULL-UP).
- 4 ONLY OPEN COLLECTOR OUTPUT WATER METERS MAY BE USED.

REVISION HISTORY					
REV	DATE	DESCRIPTION	BY	APP	DATE
A		RELEASE	11H	EV	3/25/97
B		RELEASE	22B	EV	8/28/97
D		RELEASE	1267	EV	10/3/97
D		RELEASE	1482	EV	11/2/97
E		ADDED WIRE 3	10H	EV	2/18/98
F		RELEASE SERIAL #330 0349	1743	EV	5/15/98

1 CONTACTING HEAD TYPE WATER METER

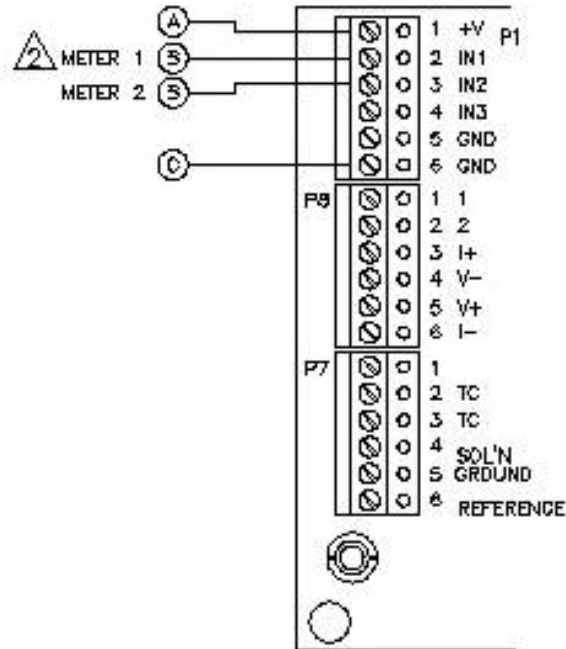
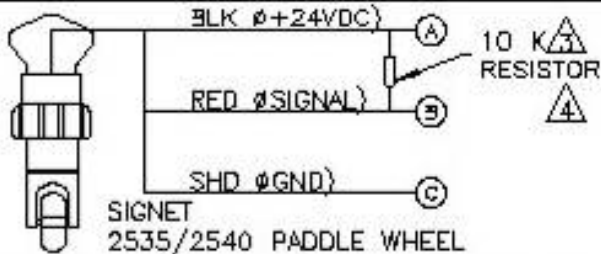
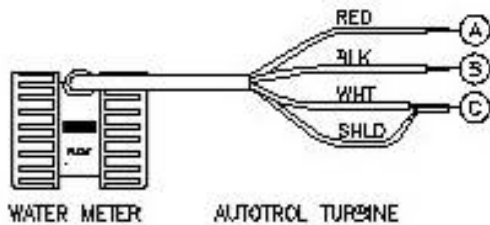
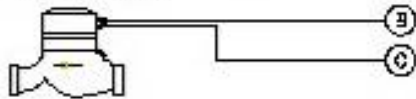

BLOCK OF INDICATORS				Lotuswood INSTRUMENTS	
DATE	REV	DESCRIPTION	BY	APP	DATE
ORDER NO.	REV	BY	DATE	APP	DATE
DESCRIPTION	REV	BY	DATE	APP	DATE
DESIGNER	REV	BY	DATE	APP	DATE
DO NOT SCALE	APPD	DATE	SCALE	SCALE	SCALE

REVISION		REVISION HISTORY			
DWG	PART	DESCRIPTION	ECO	DWN/DATE	APV/DATE
A	A	RELEASE	10042	PSG/ 5-3-06	LRS/ 7-28-06

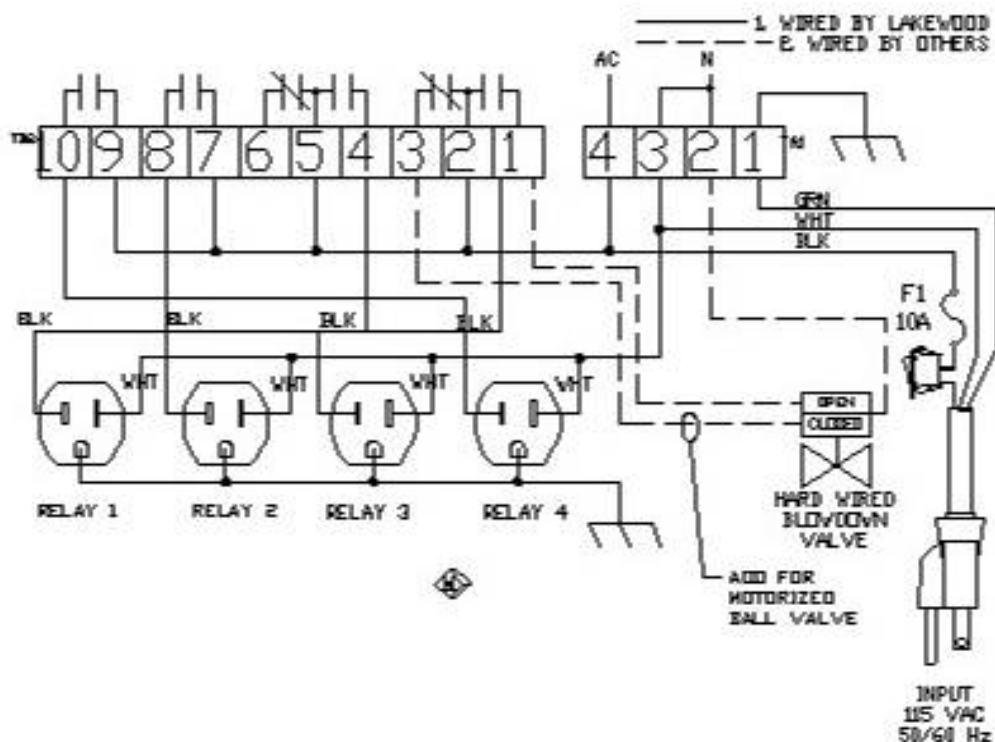

NOTICE ON REPRODUCTIONS							
THIS DRAWING, THE DESIGN AND THE PATENTS IT COVERS ARE THE PROPERTY OF LAKWOOD INSTRUMENTS INC. THEY ARE LOANED MERELY TO THE BORROWER'S EXPRESS AGREEMENT TO NOT TO BE REPRODUCED, COPIED, LOANED, DISTRIBUTED, NOT USED EXCEPT AS AUTHORIZED AND THE RESULT USE PERMITTED BY WRITTEN CONSENT GIVEN BY THE LENDER TO THE BORROWER.							
DIMENSIONING AND TOLERANCING PER ASME Y14.5M-1994					TITLE WIRING DIAGRAM, 2000 SERIES NEMA ENCLOSURE		
MATERIAL	TOLERANCES UNLESS NOTED		FINISH				
	DIMENSIONS X ± XX ± XXX ±		FINISH DWN PSG CHKD RCL DATE 5-3-06 DATE 7-28-06				
PROJECT:	APVD LRS		DATE 7-28-06		PN 1268647		REV A
LIBRARY:	VERSION		SCALE NTS		SHEET 1 DWG NO 1268647-1a		REV A

REVISION HISTORY					
REV	DESCRIPTION	EGG	D/W	DATE	AP'D
A	RELEASE	1004E	PSD	1-16-08	

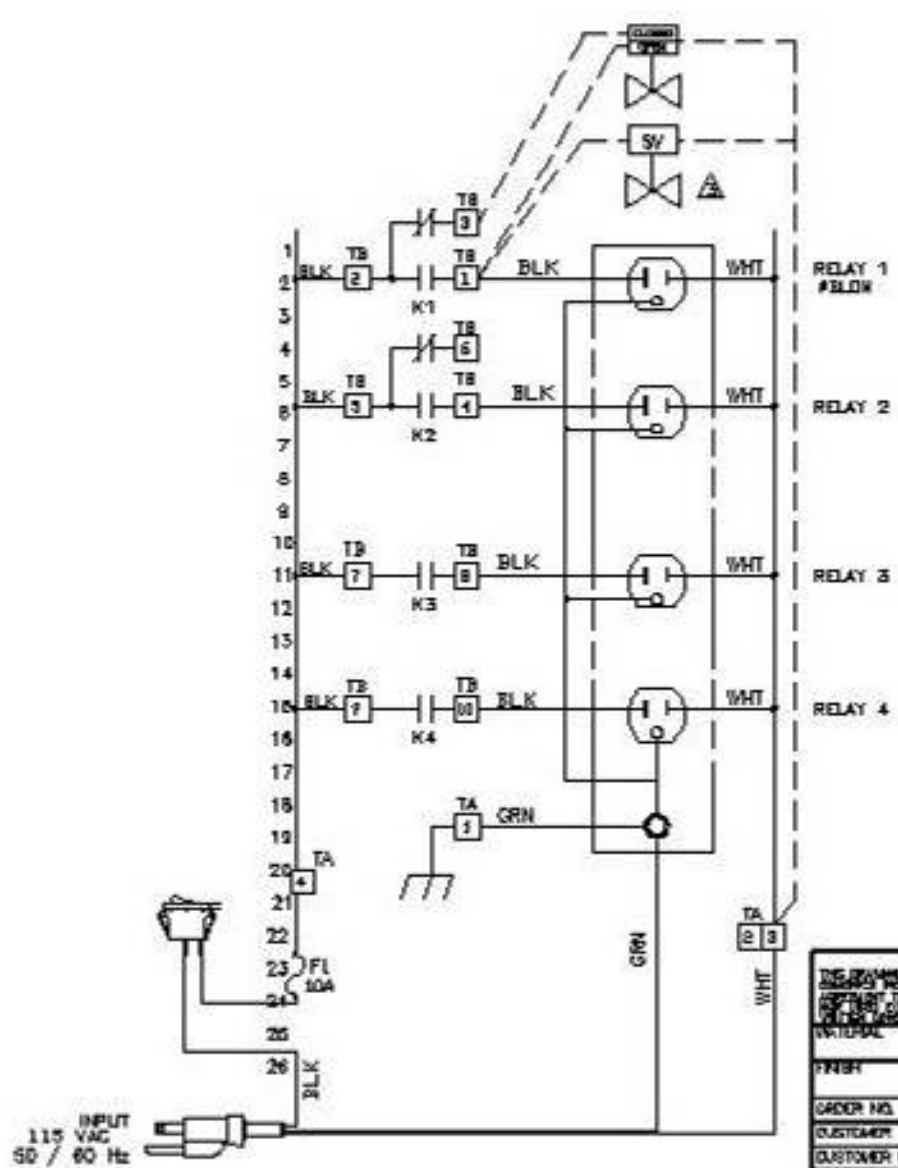

1. WIRING BY LAKEWOOD _____
2. WIRING BY OTHERS - - - - -
- ⚠ IF RECEPTACLE NOT USED, WIRE BLOWDOWN VALVE BETWEEN TB1 AND TAS
4. RELAY CONTACTS RATED 10A / 250 VAC, 1/3HP / 240 VAC

115 INPUT
VAC
50 / 60 Hz

<p>NOTICE ON REPRODUCTIONS</p> <p>THIS DRAWING IS THE PROPERTY OF LAKEWOOD INSTRUMENTS. IT IS TO BE USED FOR THE PROJECT AND SITE SPECIFICALLY IDENTIFIED HEREON. IT IS NOT TO BE REPRODUCED, COPIED, OR TRANSMITTED IN ANY FORM OR BY ANY MEANS, ELECTRONIC OR MECHANICAL, WITHOUT THE WRITTEN PERMISSION OF LAKEWOOD INSTRUMENTS.</p>			
<p>DATE: 01/16/08</p> <p>BY: JOK</p> <p>CHK: JOK</p> <p>APP: JOK</p>	<p>DATE: 11-16-08</p>	<p>TITLE: ELECTRICAL SCHEMATIC</p> <p>2000 SERIES, NEMA ENCLOSURE</p>	
<p>ORDER NO.</p> <p>CUSTOMER</p> <p>CUSTOMER LOC.</p>	<p>D/W: PSD</p> <p>DATE: 11-16-08</p> <p>DATE: 11-16-08</p>	<p>SIZE: B</p> <p>SCALE: NONE</p>	<p>REV: A</p> <p>DATE: 11-16-08</p> <p>FILE TYPE: DWG</p> <p>SHEET 1 OF 1</p>

NOTES: UNLESS OTHERWISE SPECIFIED:
 ⚠️ STANDARD FOUR CONDUCTOR TELEPHONE CABLE
 UP TO 50 FEET IN LENGTH MAY BE SUBSTITUTED.

REVISION HISTORY					
REV	DATE	DESCRIPTION	ISS	DES	CHK
A		RELEASE	02/87	MLJ	V/ML
B		DESIGN	02/87	MLJ	L/RS
C		REVISED	10/87	W	TS/ML/ST
D		REVISED	10/87	W	TS/ML/ST

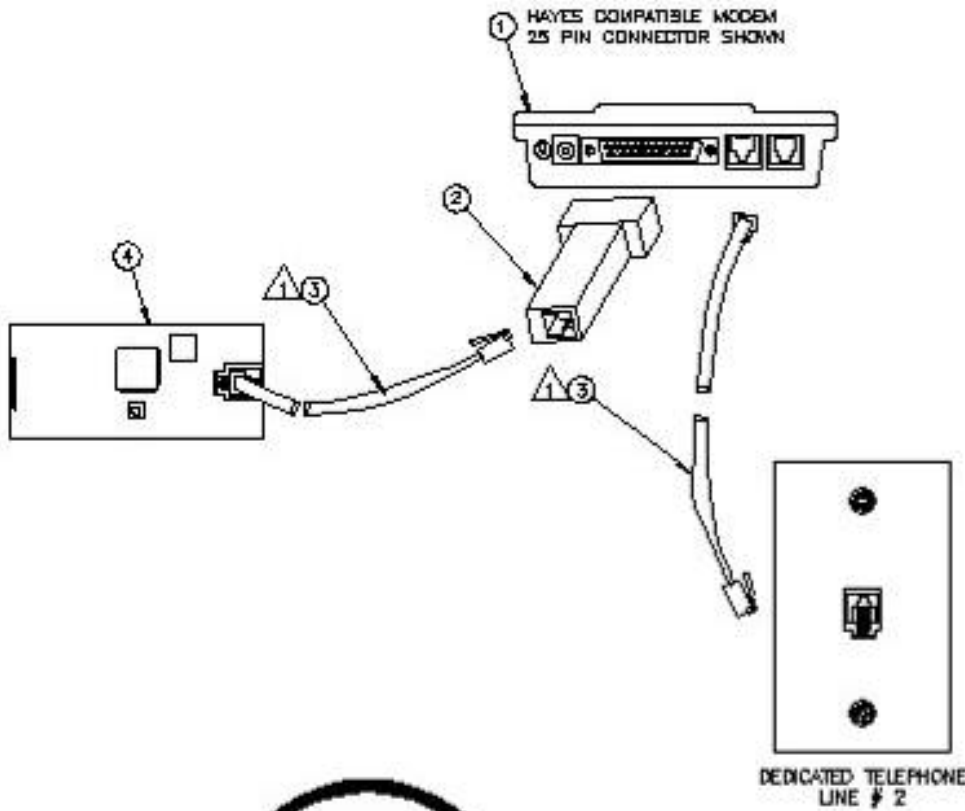

PERSONAL COMPUTER WITH MODEM

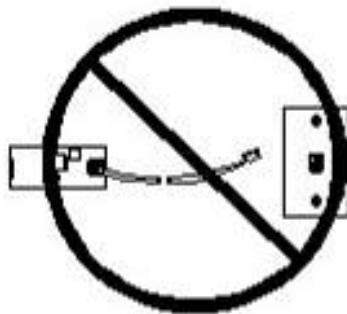
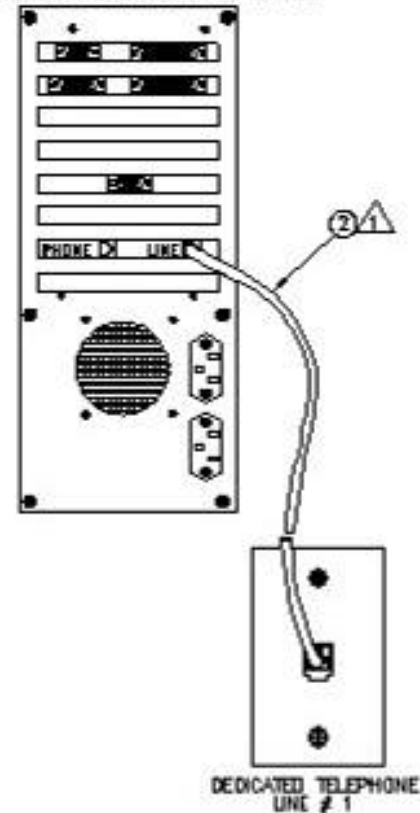

DO NOT PLUG RJ11 DIRECTLY INTO TELEPHONE LINES

1	RESL	RESL COM MODE	ASSEMBLED PCB, 14-2000	4
1	60336	CABLE, RJ11, 25 FT.		3
1	6776C	ADAPTER	25 P MALE D CONN TO RJ11 DTE	2
1	6774D	MODEM	HAYES COMPATIBLE	1
BUILT UP				
WORK IN PROGRESS				
GENERAL				
TITLE DATE DRAWN BY CHECKED BY DESIGNED BY APPROVED BY DATE			TITLE COORDINATOR DATE	
PROJECT NO. DEPT. OFFICE DIV. PROJ. NO.			PROJECT NO. 1109708-1d REV. D	
TO: 100% SCALE BY:			DRAWN BY:	

4

1

3

4

2

1

1

1

A

D

C

B

NOTES: UNLESS OTHERWISE SPECIFIED;

1. STANDARD FOUR CONDUCTOR TELEPHONE CABLE UP TO 50 FEET IN LENGTH MAY BE SUBSTITUTED.

REVISION HISTORY					
REV	DATE	DESCRIPTION	CHK	APP	DATE
A	RELEASE	RELEASE	1367	DJ	10/8/97
B	REWORK	REWORK	1367	DJ	10/8/97
B	REWORK	REWORK	1465	DJ	11/14/97

PERSONAL COMPUTER WITH MODEM

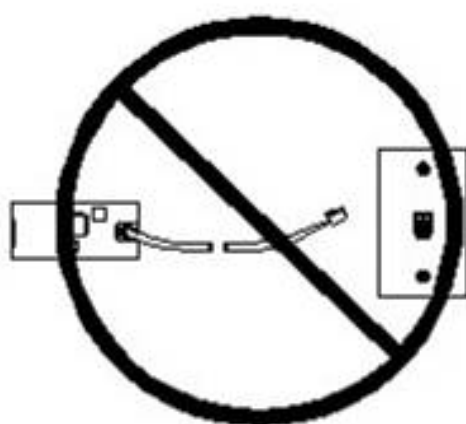
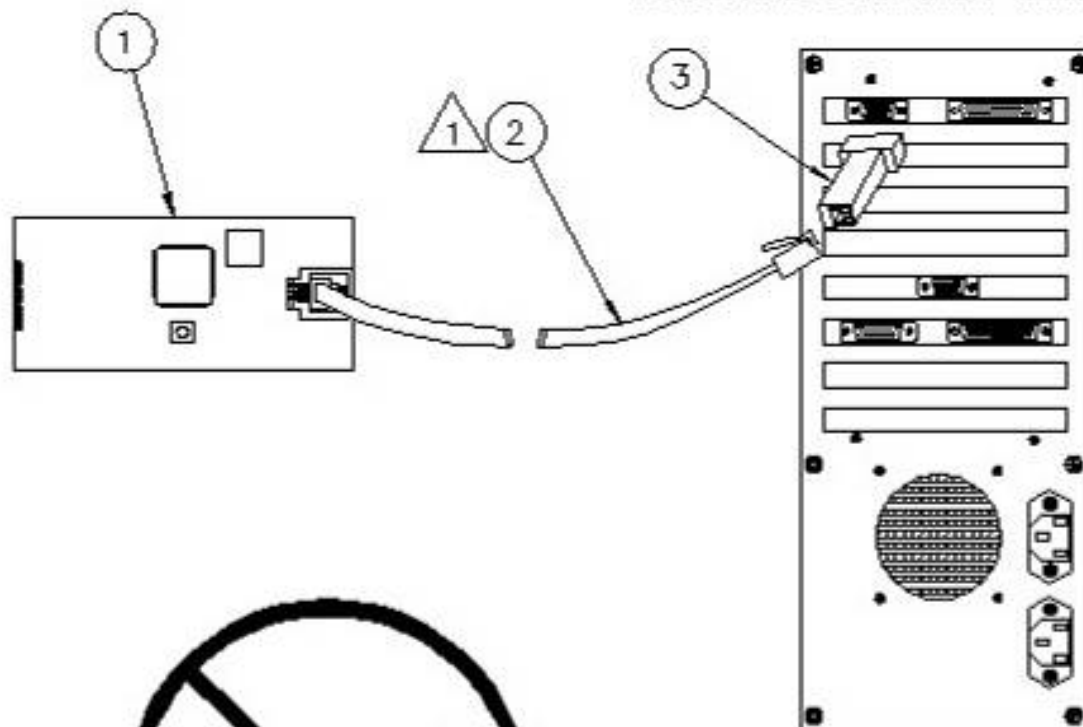

DO NOT PLUG RS232 DIRECTLY INTO TELEPHONE LINES

1	87300	ADAPTER, 9 PIN	MALE COM1 TO RJ11 DTE	3
1	88336	CABLE, P-81	25 FT	2
1	RS232	RS232 COM MODE	ASSEMBLED PCB, M-2000	1
SUPPLY LIST				
NOTE ON REPRESENTATION				
ORDER NO. _____ DATE _____ QUANTITY _____ UNIT PRICE _____ TOTAL PRICE _____		<p>INSTALLATION LAYOUT RS232 DIRECT CONNECT TO 9 PIN RS232</p> <p>1109700-00</p>		

For more information call toll free in the USA (800) 228-0839

Manufactured in the USA

Lakewood Instruments

7838 North Faulkner Road, Milwaukee, WI 53224 USA

Phone (800) 228-0839 • Fax (414) 355-3508

<http://www.lakewoodinstruments.com>